

**GE** series

SINGLE CYLINDER

GE725F - GE625F - GE525F



Lonati

# SINGLE CYLINDER

GE725F - GE625F - GE525F

## SBYS DEVICE

for automatic linking, increased reliability and productivity compared to the previous series

## KNITTING HEAD

designed to knit high quality items and ensure constant reliability over time

## STEPPING MOTORS

with absolute encoder for angular position control

## NEW ELECTRONICS

9" high resolution touch screen display. New user friendly interface. Ethernet, WiFi, NFC connections, Bluetooth is also available for future developments

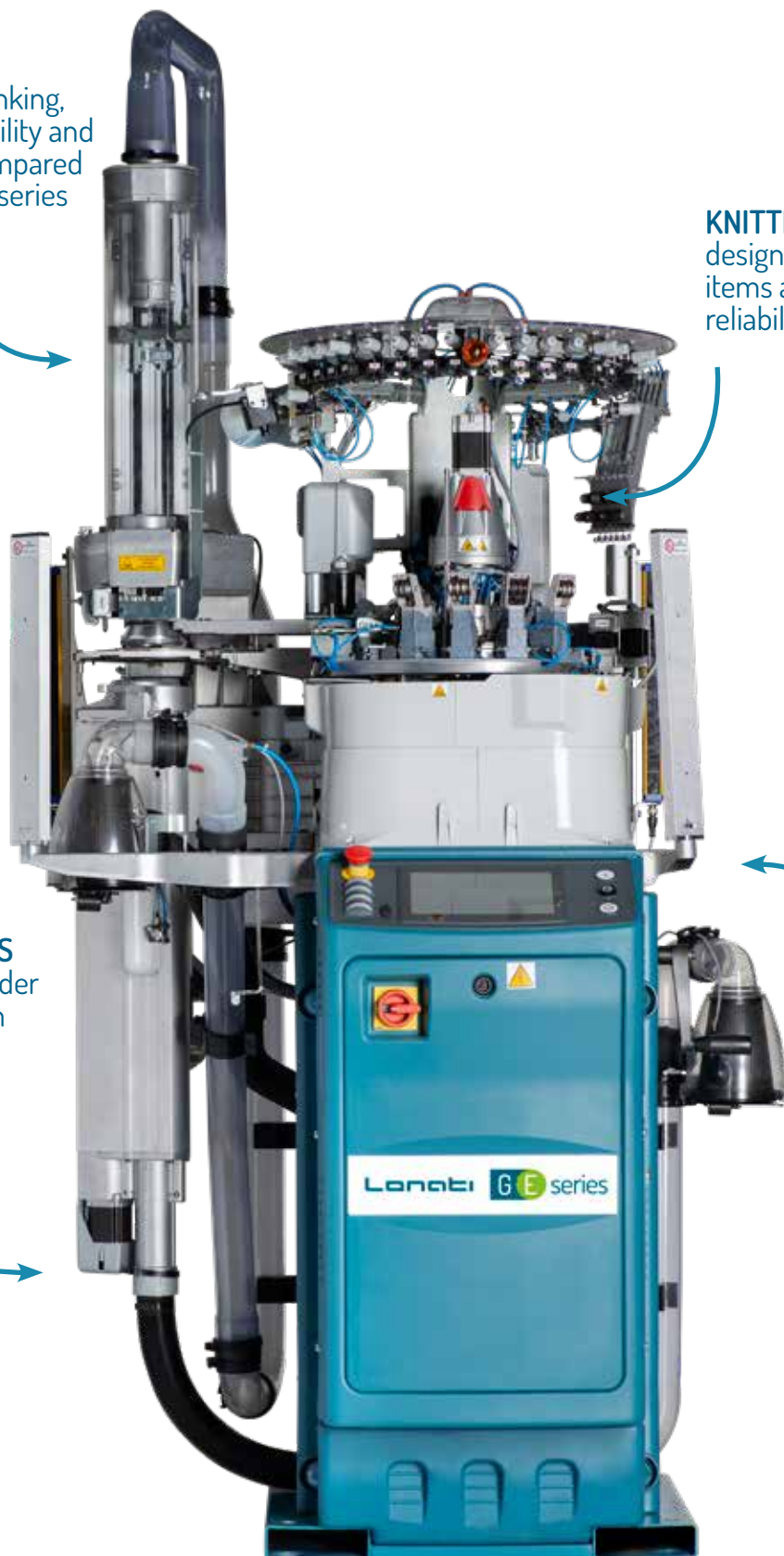



All images in this brochure are indicative and not binding.

## SINGLE CYLINDER

### GE725F - GE625F - GE525F

2 feeds single cylinder for men's socks machines are designed to increase productivity still ensuring best quality. They are available in different diameters with different numbers of needles. Automatic linking with the latest version of the SBYS device, performing a "real linking" technique. Advantages are remarkable: superior quality sock finishing, more comfort and resistance compared to socks made using conventional systems. New electronics provides control and execution of all machine commands. Drawings and articles are created and managed by Digraph 3 Plus software package, which contains a full collection of styles the operator can combine in different ways to obtain the desired results.

- 5 colors pattern on single feed course, plain knit or terry
- Reciprocated heel and toe in different sizes and 3D effects
- 28 yarn fingers
- Rising dial and finger plate with stepping motor
- 9 electronic actuators for needle selection
- Brushless coaxial main motor

#### MACHINE DIMENSIONS



Length max 127.3 cm  
Depth max 114.8 cm  
Height max 228 cm

#### MACHINE WEIGHT



ca. 320 Kg

# SINGLE CYLINDER

GE725F - GE625F - GE525F

## TECHNICAL DATA

MODEL	CYLINDER DIAMETER	GAUGE	NEEDLE THICKNESS
GE725F	3 1/2	7 1/2 to 14	0.85 - 0.70 - 0.60 mm
GE625F	3 3/4	from 9 to 17	0.85 - 0.70 - 0.60 mm
GE525F	4"	from 8 1/2 to 16	0.85 - 0.70 - 0.60 mm

Above data are indicative and not binding.

## STANDARD DEVICES

- Stepper motor electric dial with adjustable height
- Stitch cam feeds: 1 and 2 with three different heights.
- Motorized sinker cap for sinker pressure and angular position
- 9" high resolution touch screen display
- Yarn sliding sensors guard cleaning device
- Heel yarn recover device with four positions
- 2 stepper motor controlled adjustable suction valves
- 14 color yarn fingers
- 9 yarn fingers on first feed, 6 on second feed
- Yarn creel
- USB port
- Circular yarn cutter with mechanical stop
- 1 yarn finger on laid-in elastic feed

## MAIN OPTIONAL DEVICES

- LGL Eco Power or Eco Compact yarn storage feeder, also available with "Attivo" electronic brake version
- Dinema GRYF positive yarn feeders
- Elastic yarn positive feeders, for compression socks
- Dinema Plus elastane positive feeders
- Motorized stitch cams
- Motorized raising stitch device for sock extraction
- Motorized sinkers cap for sinkers pressure
- Antitwist device
- Footlet device
- Inside-out sock ejection device
- G-Flot device
- G-Flot 2 device
- Elastane extra pliers device
- Recover yarn device, 6 positions
- Yarn trimming circular cutter with adjustable speed
- Lower sock-turning device with rotating tube
- Linking device and yarnfingers inspection led lamps
- Preparation for storage feeder "Unifeeder 2" by BTSR
- Ethernet board for connection to Dinema Nautilus data collector system
- Second elastic yarn finger on second feed
- Yarn sliding control sensors, Dinema ISPY
- Pneumatic yarn tensioner for covered elastane
- Suction fan

## POSSIBLE KNITTING

The standard machine can perform the following knittings

- Mesh, tuck and float stitch, jacquard, 2 feeds, plain knit or terry
- 5 colors pattern plus ground color, tuck and float stitch, 1 feed, plain knit or terry
- With laid-in elastic: 4 colors pattern plus ground color, mesh, tuck and float stitch, 1 feed, plain knit or terry
- Laid-in elastic on 2 feeds, that is 1 elastic course every 2 knitted courses, plain knit or terry
- With the second elastic yarn finger 4 colors pattern on course plus ground, tuck and float stitch, one feed, plain knit or terry
- With the second elastic yarn finger 3 colors pattern on course plus ground, mesh, tuck and float stitch, 1 feed, plain knit and terry

# SINGLE CYLINDER

## GE725F - GE625F - GE525F

**Lonati**

### NUMBER OF COLORS

Number of colors	5 colors on course plus ground color, one feed
------------------	--

### PERFORMANCES

	3" 1/2 3" 3/4 4" CYLINDERS
KNITTING FEATURES	Patterns or selections 300 rpm Plain knit without pattern, "high speed" sinker cap 350 rpm
MAXIMUM SPEED	350 rpm

Above data are indicative and not binding.

DISCLAIMER: maximum speed may vary depending on yarn, knitting, lubrication etc

### GAUGE

		GAUGE																							
Model	ø	6½	7	7½	8	8½	9	9½	10	10½	11	11½	12	12½	13	13½	14	14½	15	15½	16	16½	17		
GE525F	4"					108				116			128	136	144			156		168	176	180	188	192	200
		Needle thickness 0.85 mm																							
		Needle thickness 0.70 mm							Needle thickness 0.70 mm							Needle thickness 0.60 mm									
GE625F	3"3/4						108	112	116	120	128	132	136	144		156	160	168		176	180	188	192	200	
		Needle thickness 0.85 mm																							
		Needle thickness 0.70 mm							Needle thickness 0.70 mm							Needle thickness 0.60 mm									
GE725F	3"1/2			84	88	96	100		108	112	116	120	128	132		144		156							
		Needle thickness 0.85 mm																							
		Needle thickness 0.70 mm																							

Above data are indicative and not binding.

#### DISCLAIMER:

All features in the brochure are for information only and subject to change without any prior notice.

For a complete list of available options, please contact Lonati sales network.

The Company accepts no liability for improper use of machinery.

Lonati is recommending needles from  
**GROZ-BECKERT®**

# SINGLE CYLINDER

GE725F - GE625F - GE525F

## NOISE LEVEL (Maximum noise output for GE series models)

Noise pressure level on reference surface = LPA 79,5 dB - Noise power level = LWA 96,6 dB - Peak= 109,3 dB

## LUBRICANTS

Average consumption for 100 dozens= 270 gr. Lonati recommends: Kluber Madol 183 Supreme - Fuchs Renolin Trax 16C - VICKERLUBE SOCK 46

## GREASE

For seals, bearings etc: Lonati recommends: TechnolubeSeals Damping grease Nyogel 774F-1

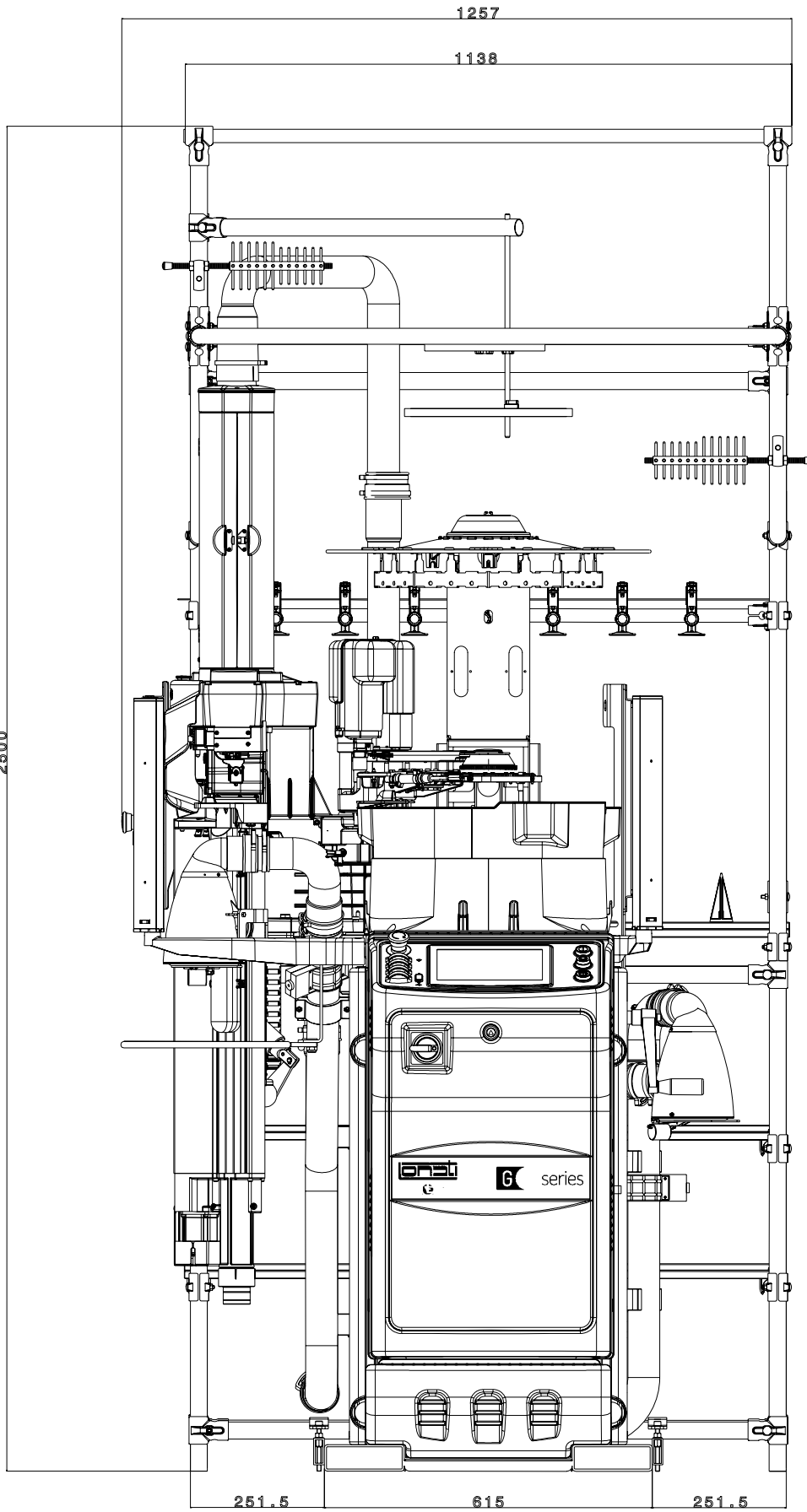

DESCRIPTION	CODE	NR. OF REELS	WEIGHT KG.	NOTES
Yarn creel	G3930706	23	51	Standard version
Yarn creel	G3930707	23	51	Version with BTR sensors

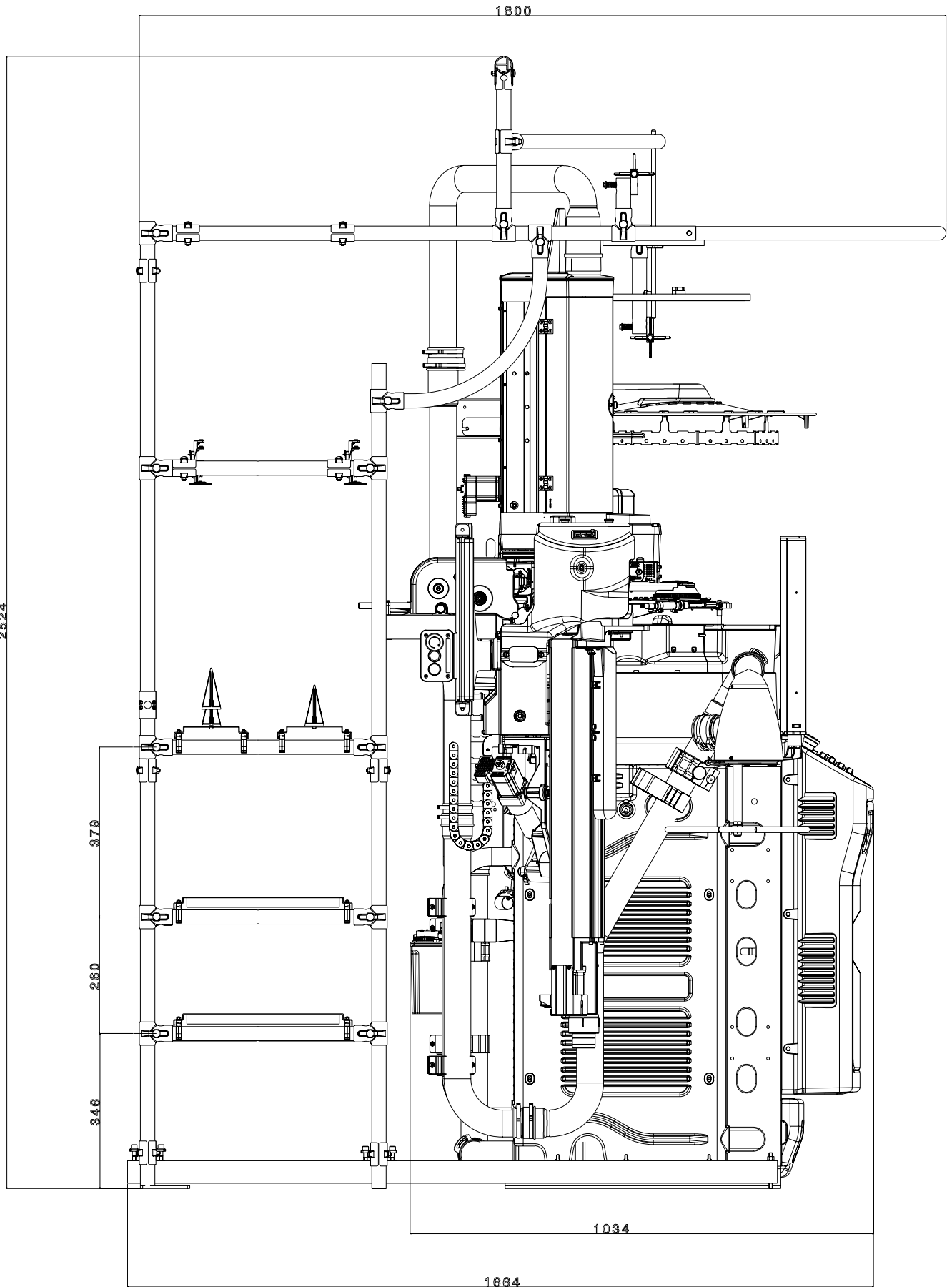

DESCRIPTION	CODE	NR. OF REELS	WEIGHT KG.	NOTES
Yarn creel	G3930706	23	51	Standard version
Yarn creel	G3930707	23	51	Version with BTR sensors



Lonati

