

G E series

SINGLE CYLINDER

GE715F - GE716F - GE615F

GE616F - GE515F - GE516F



Lonati

SINGLE CYLINDER

GE715F - GE716F - GE615F - GE616F - GE515F - GE516F

SBYS DEVICE,
for automatic linking,
increased reliability
and productivity
compared to the
previous series.

KNITTING HEAD
designed to knit high quality items
and ensure constant reliability
over time.

STEPPING MOTORS
with absolute encoder
for angular position
control.

NEW ELECTRONIC
9" high resolution
touch screen
display. New user
friendly interface.
Ethernet, Wifi, NFC
connections,
Bluetooth is also
available for future
developments.

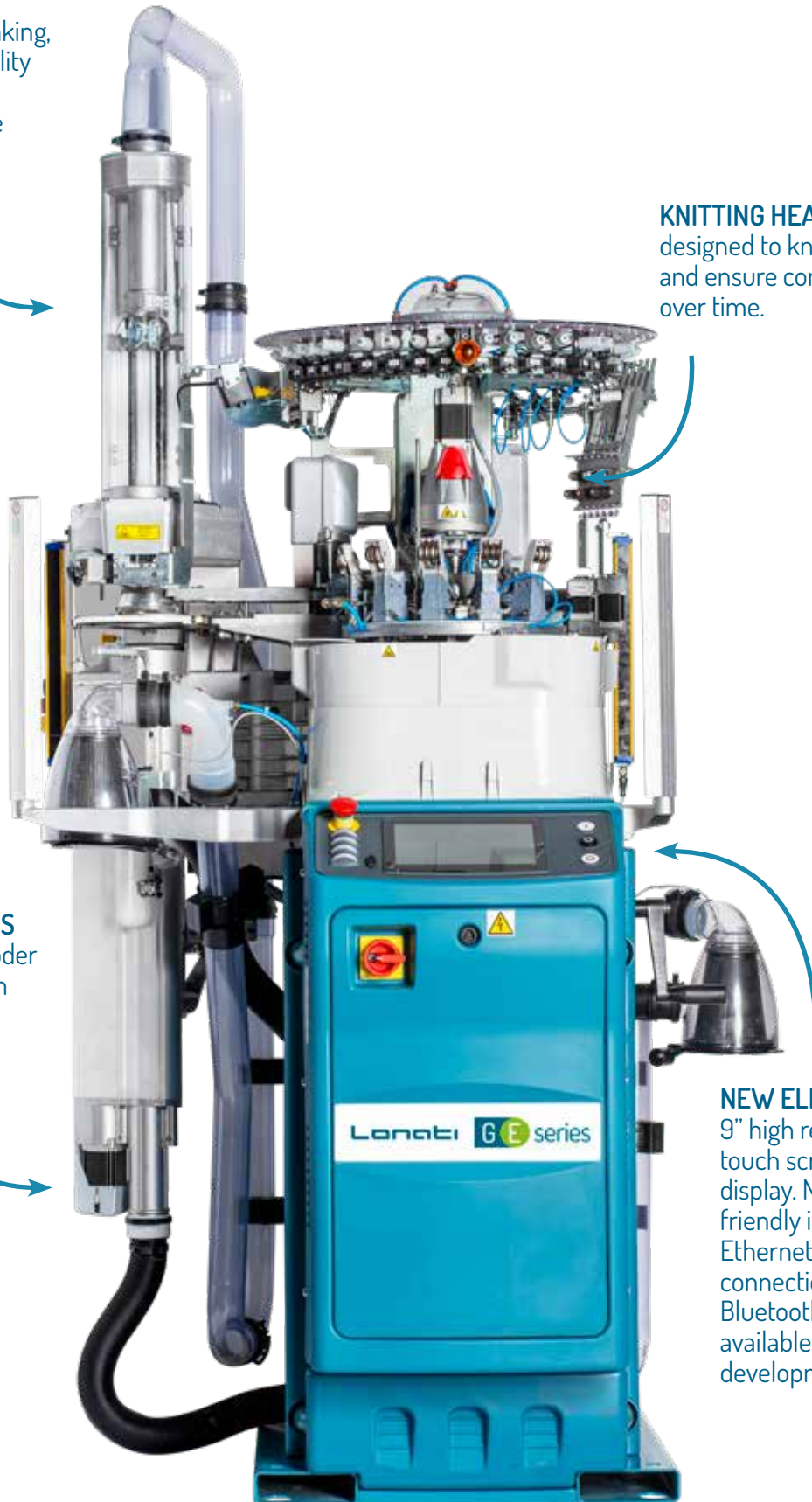

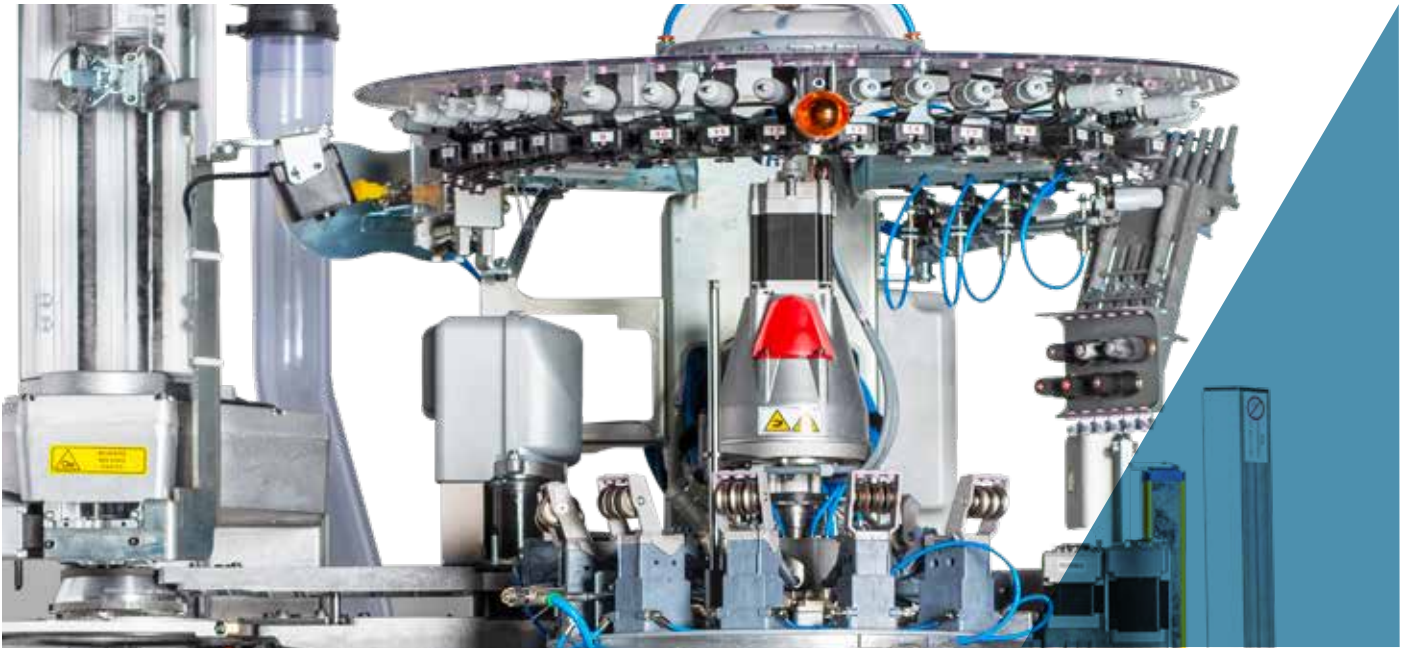

All images in this brochure are indicative and not binding.

SINGLE CYLINDER

GE715F - GE716F - GE615F - GE616F - GE515F - GE516F

1 feed machines are the best sellers of the single cylinder for men's socks as, thanks to their versatility, they can produce several different items, from the very simple to the most complex, without compromising on quality and efficiency. They are available in two versions, with five or six colors on course and in different diameters and numbers of needles. Automatic linking with the latest version of the SBYS device, performing a "real linking" technique. Advantages are remarkable: superior quality sock finishing, more comfort and resistance compared to socks made using conventional systems. New electronics provides control and execution of all machine commands. Drawings and articles are created and managed by Digraph 3 Plus software package, which contains a full collection of styles the operator can combine in different ways to obtain the desired results.

- 5 or 6 colors pattern on course according to the model, plain knit or terry
- Reciprocated heel and toe in different sizes and 3D effects
- 25 or 28 yarn fingers, according to the model
- Rising dial and finger plate with stepping motor
- Electronic actuators for needle selection, 8 or 9 according to the model
- Brushless coaxial main motor

MACHINE DIMENSIONS



Length max 127.3 cm
Depth max 114.8 cm
Height max 228 cm

MACHINE WEIGHT



ca. 320 Kg

CERTIFICATION



Green Label

SINGLE CYLINDER

GE715F - GE716F - GE615F - GE616F - GE515F - GE516F

TECHNICAL DATA

MODEL	CYLINDER DIAMETER	GAUGE	NEEDLE THICKNESS
GE715F	3"1/2	7 1/2 to 14	0.85 - 0.70 - 0.60 mm
GE716F	3"1/2	7 1/2 to 14	0.85 - 0.70 - 0.60 mm
GE615F	3"3/4	from 9 to 17	0.85 - 0.70 - 0.60 mm
GE616F	3"3/4	from 9 to 17	0.85 - 0.70 - 0.60 mm
GE515F	4"	from 8 1/2 to 16	0.85 - 0.70 - 0.60 mm
GE516F	4"	from 8 1/2 to 16	0.85 - 0.70 - 0.60 mm

Above data are indicative and not binding.

STANDARD DEVICES

- Stepper motor electric dial with adjustable height
- Stitch cam feed: 1 with 3 different heights.
- Motorized sinker cap for sinker pressure and angular position
- 9 " high resolution touch screen display
- Yarn sliding sensors guard cleaning device
- Heel yarn recover device with four positions
- 2 stepper motor controlled adjustable suction valves
- 9 yarnfingers on stitch feed
- Yarn creel
- USB port
- 15 or 18 color yarnfingers, according to model
- Circular yarn cutter with mechanical stop
- 1 yarnfinger on laid-in elastic feed

MAIN OPTIONAL DEVICES

- LGL Eco Power or Eco Compact yarn storage feeder, also available with "Attivo" electronic brake version
- Dinema GRYF positive yarn feeders
- Elastic yarn positive feeders, for compression socks
- Dinema Plus elastane positive feeders
- Motorized stitch cams
- Motorized knit rising tube
- Antitwist device
- Footlet device
- Inside-out sock ejection device
- G-Flot device
- G-Flot 2 device
- Elastane extra pliers device
- Yarn recover device, 6 positions
- Yarn trimming circular cutter with adjustable speed
- Lower sock-turning device with rotating tube
- Linking device and yarnfingers inspection led lamps
- Preparation for storage feeder "Unifeeder 2" by B TSR
- Ethernet board for connection to Dinema Nautilus data collector system
- Second elastic yarn finger
- Yarn sliding control sensors, Dinema ISPY
- Pneumatic yarn tensioner for covered elastane
- Suction fan

POSSIBLE KNITTING

The standard machine can perform the following knittings

- 5 or 6 colors pattern, according to model, plus ground color, mesh, tuck and float stitch, plain knit or terry
- With laid-in elastic: 5 or 6 colors pattern, according to model, plus ground, tuck and float stitch, plain stitch or terry
- With laid-in elastic: 4 or 5 colors pattern, according to model, plus ground, mesh, tuck and float stitch, plain knit or terry

SINGLE CYLINDER

GE715F - GE716F - GE615F - GE616F - GE515F - GE516F



NUMBER OF COLORS

Number of colors	GE715F - GE615F - GE515F 5 colors on course plus ground GE716F - GE616F - GE516F 6 colors on course plus ground
------------------	--

PERFORMANCES

		3 1/2, 3 3/4, 4" CYLINDERS
KNITTING FEATURES		Patterns or selections or terry 300 rpm Plain knit without pattern with "high speed" sinkers cap 350 rpm
MAXIMUM SPEED		350 rpm

Above data are indicative and not binding.

DISCLAIMER: maximum speed may vary depending on yarn, knitting, lubrication etc

GAUGE

		GAUGE																						
Model	ø	6 1/2	7	7 1/2	8	8 1/2	9	9 1/2	10	10 1/2	11	11 1/2	12	12 1/2	13	13 1/2	14	14 1/2	15	15 1/2	16	16 1/2	17	
GE515F	4"					108			116		128	136	144		156		168	176	180	188	192	200		
		Needle thickness 0.85 mm																						
		Needle thickness 0.70 mm						Needle thickness 0.70 mm						Needle thickness 0.60 mm										
GE615F	3 3/4"						108	112	116	120	128	132	136	144		156	160	168		176	180	188	192	200
		Needle thickness 0.85 mm																						
		Needle thickness 0.70 mm						Needle thickness 0.70 mm						Needle thickness 0.60 mm										
GE715F	3 1/2"			84	88	96	100		108	112	116	120	128	132		144		156						
		Needle thickness 0.85 mm																						
		Needle thickness 0.70 mm																						

		GAUGE																						
Model	ø	6 1/2	7	7 1/2	8	8 1/2	9	9 1/2	10	10 1/2	11	11 1/2	12	12 1/2	13	13 1/2	14	14 1/2	15	15 1/2	16	16 1/2	17	
GE516F	4"					108			116		128	136	144		156		168	176	180	188	192	200		
		Needle thickness 0.85 mm																						
		Needle thickness 0.70 mm						Needle thickness 0.70 mm						Needle thickness 0.60 mm										
GE616F	3 3/4"				96		108	112	116	120	128	132	136	144		156	160	168		176	180	188	192	200
		Needle thickness 0.85 mm																						
		Needle thickness 0.70 mm						Needle thickness 0.70 mm						Needle thickness 0.60 mm										
GE716F	3 1/2"			84	88	96	100		108	112	116	120	128	132		144		156						
		Needle thickness 0.85 mm																						
		Needle thickness 0.70 mm																						

Above data are indicative and not binding.

DISCLAIMER:

All features in the brochure are for information only and subject to change without any prior notice.

For a complete list of available options, please contact Lonati sales network.

The Company accepts no liability for improper use of machinery.

Lonati is recommending needles from
GROZ-BECKERT®

SINGLE CYLINDER

GE715F - GE716F - GE615F - GE616F - GE515F - GE516F

NOISE LEVEL (Maximum noise output for GE series models)

Noise pressure level on reference surface = LPA 79,5 dB - Noise power level = LWA 96,6 dB - Peak= 109,3 dB

LUBRICANTS

Average consumption for 100 dozens= 270 gr. Lonati recommends: Kluber Madol 183 Supreme - Fuchs Renolin Trax 16C - VICKERLUBE SOCK 46

GREASE

For seals, bearings etc: Lonati recommends: TechnolubeSeals Damping grease Nyogel 774F-1

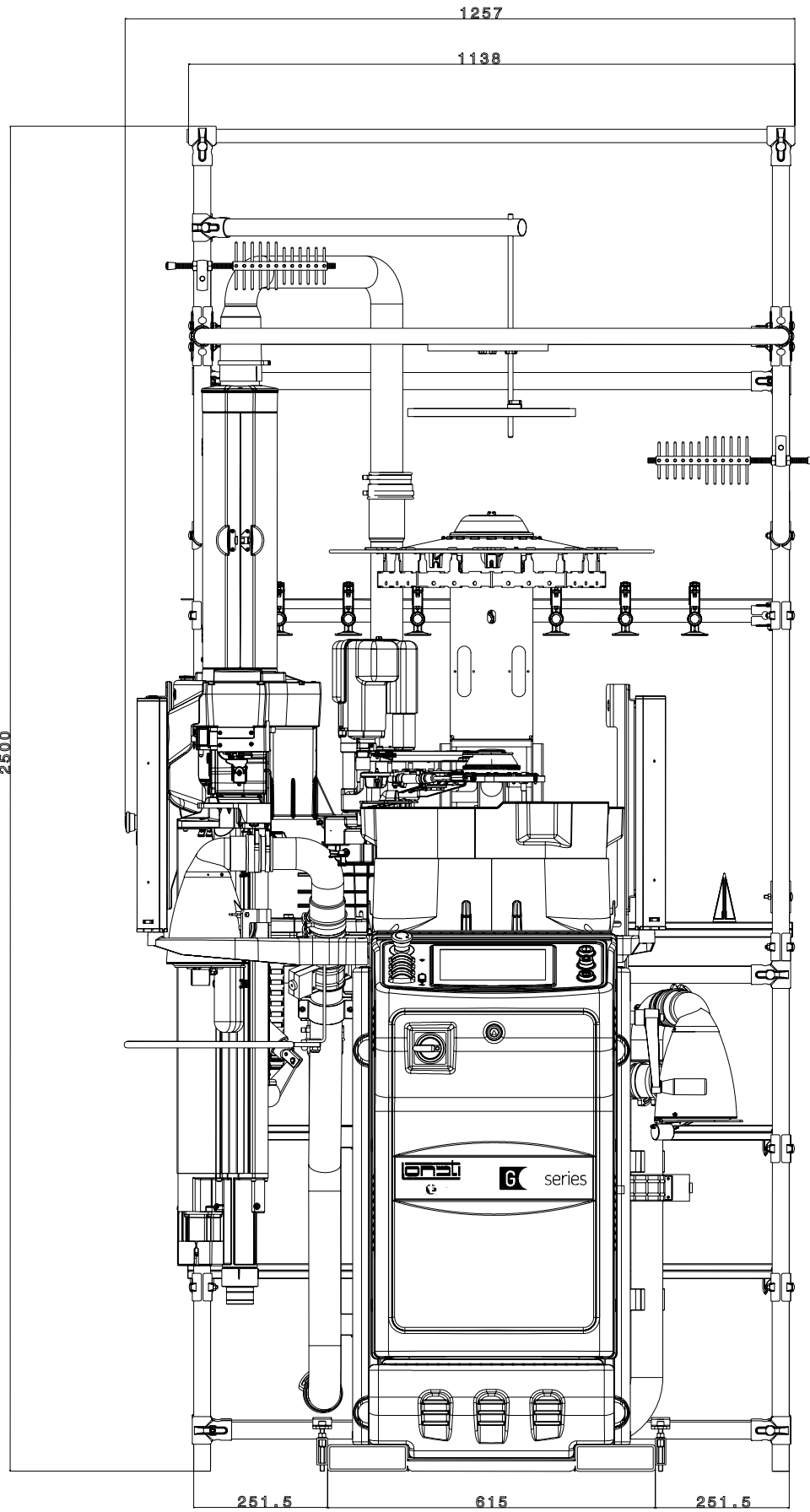

DESCRIPTION	CODE	NR. OF REELS	WEIGHT KG.	NOTES
Yarn creel	G3930706	23	51	Standard version
Yarn creel	G3930707	23	51	Version with BTR sensors

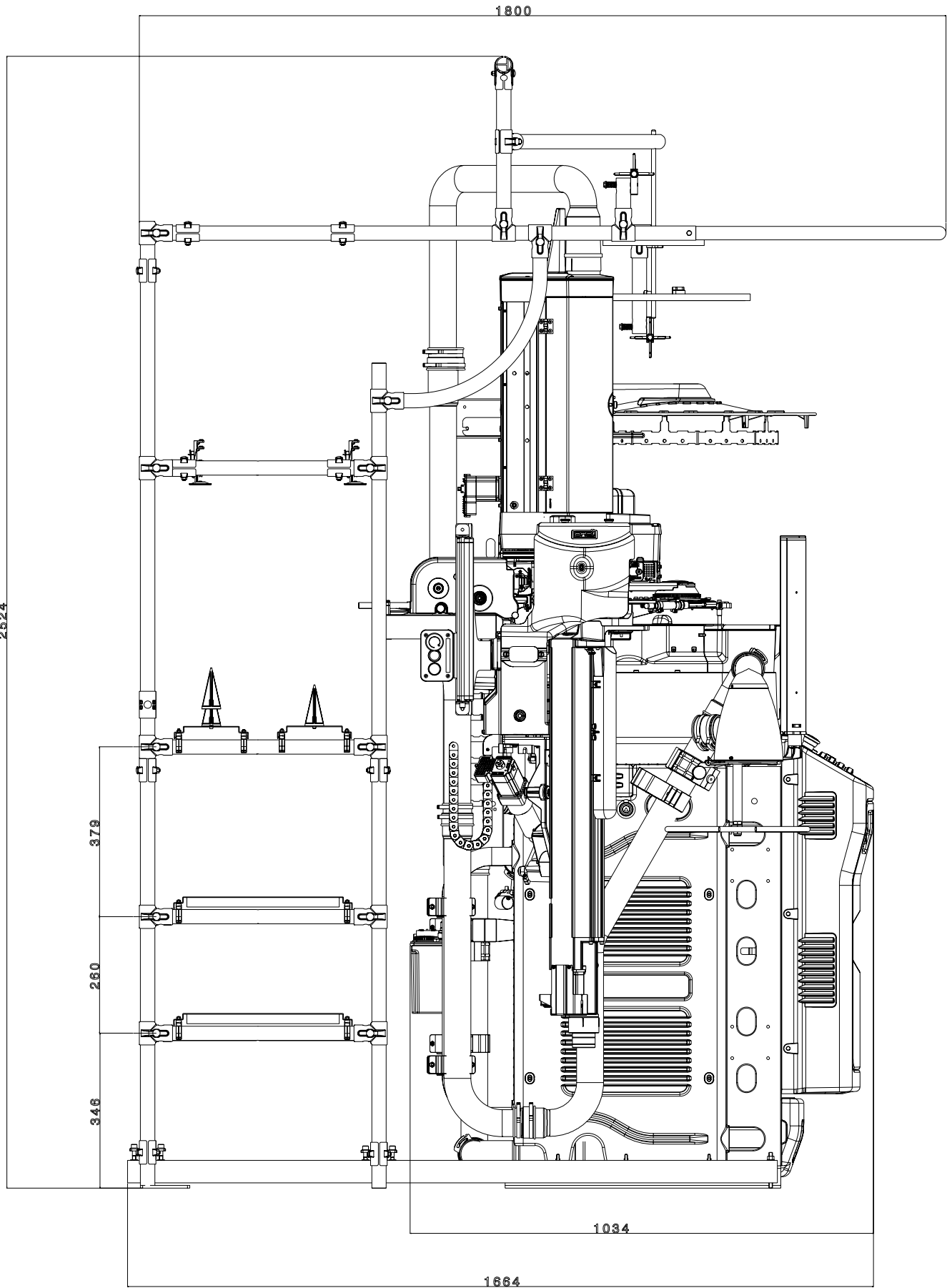

DESCRIPTION	CODE	NR. OF REELS	WEIGHT KG.	NOTES
Yarn creel	G3930706	23	51	Standard version
Yarn creel	G3930707	23	51	Version with BTR sensors

Lonati

