

G **E** series

SINGLE CYLINDER

GE625DF



Lonati

SINGLE CYLINDER GE625DF

SBYS DEVICE,
for automatic linking,
increased reliability and
productivity compared
to the previous series

KNITTING HEAD
designed to knit high quality
items and ensure constant
reliability over time

**STEPPING
MOTORS**
with absolute
encoder for
angular position
control

NEW ELECTRONICS
9" high resolution touch
screen display. New
user friendly interface.
Ethernet, WiFi, NFC
connections, Bluetooth
is also available for
future developments

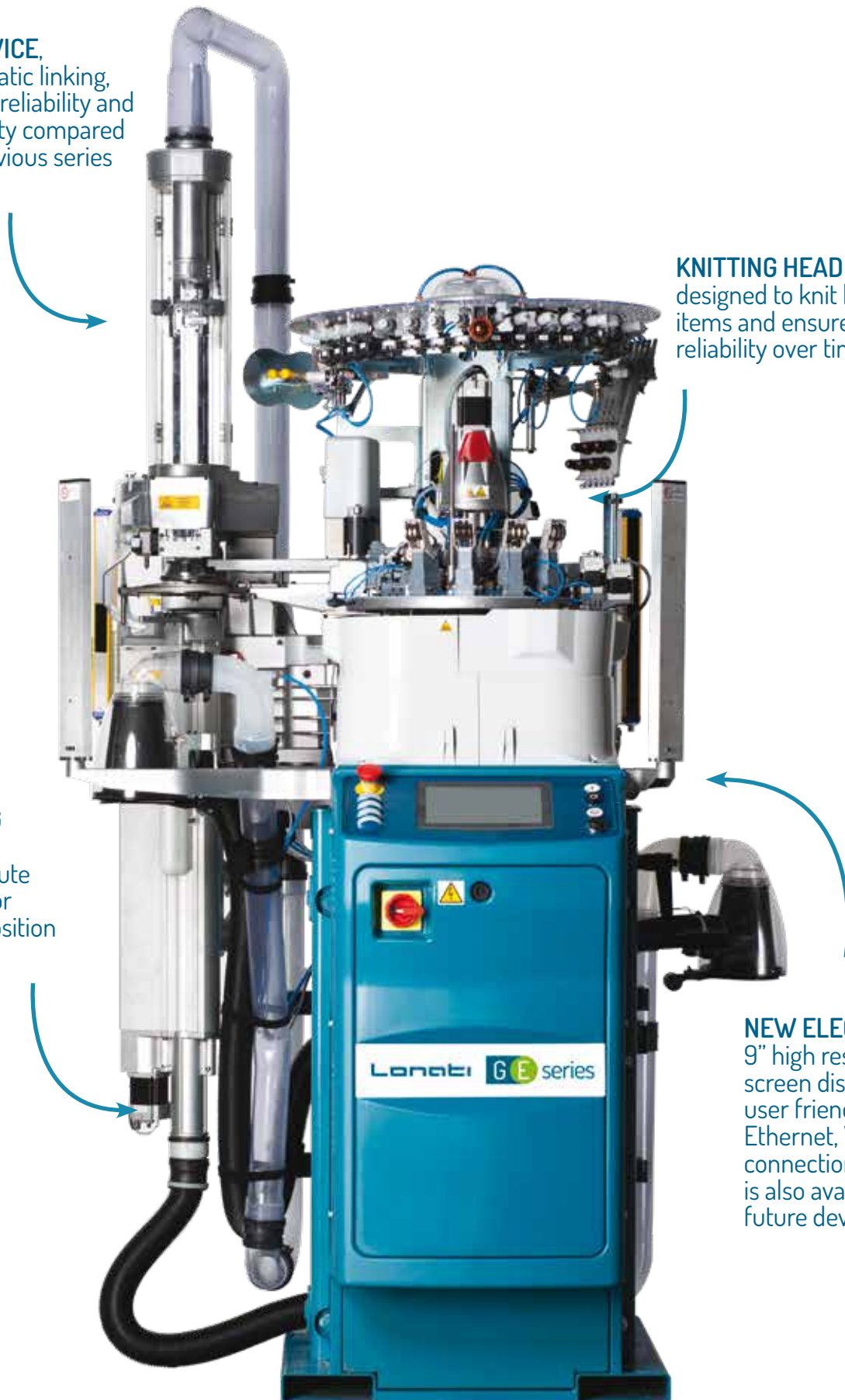

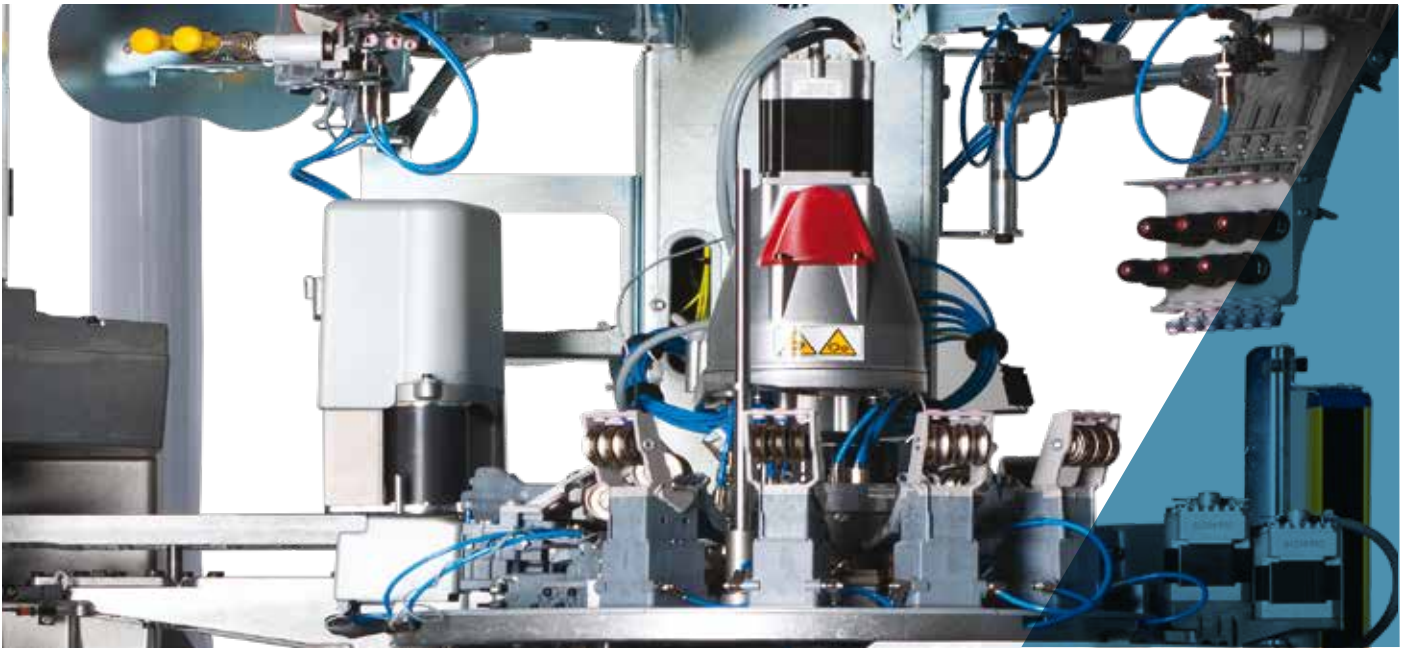

All images in this brochure are indicative and not binding.

SINGLE CYLINDER GE625DF

2 feeds single cylinder for men's socks machines are designed to increase productivity still ensuring best quality. Automatic linking with the latest version of the SBYS device, performing a "real linking" technique. Advantages are remarkable: superior quality sock finishing, more comfort and resistance compared to socks made using conventional systems. New electronics provides control and execution of all machine commands. Drawings and articles are created and managed by Digraph 3 Plus software package, which contains a full collection of styles the operator can combine in different ways to obtain the desired results.

- Five colours pattern on course in single feed, with selected terry or plain fabric. The selected terry is possible also with double feeds articles.
- Reciprocated heel and toe in different sizes and 3D effects.
- Number of yarn fingers: twenty seven
- Rising dial and finger plate, with stepping motor
- Nine electronic actuators for needle selection. Two actuators for the selection of the sinker.
- Brushless coaxial main motor.

MACHINE DIMENSIONS



Length max 116.8 cm
Depth max 103.7 cm
Height max 226.0 cm

MACHINE WEIGHT



Machine ca. 320 Kg
Yarn Creel ca. 46 Kg

CERTIFICATION



Green
Label

SINGLE CYLINDER

GE625DF

TECHNICAL DATA

MODEL	CYLINDER DIAMETER	GAUGE	NEEDLE THICKNESS
GE625DF	3"3/4	from 9 to 17	0.85 - 0.70 - 0.60 mm

Above data are indicative and not binding.

STANDARD DEVICES

- Stepper motor electric dial with adjustable height.
- Stitch cam feeds: first and second with three different heights.
- Motorized sinker cap for sinker pressure and angular position.
- High resolution 9" touch screen display.
- Yarn sliding sensors guard cleaning device.
- Heel yarn recover device with four positions.
- Two stepper motor controlled adjustable suction valves.
- Fourteen color yarn finger.
- Nine yarn fingers on first feed, six on second feed.
- Yarn creel.
- USB port.
- Circular yarn cutter with mechanical stop.
- One yarn finger on laid-in elastic feed.

MAIN OPTIONAL DEVICES

- LGL Eco Power or Eco Compact yarn storage feeder, also available with "Attivo" electronic brake version
- Dinema GRYF positive yarn feeders
- Elastic yarn positive feeders, for compression socks
- Dinema Plus elastane positive feeders
- Motorized stitch cams
- Motorized raising stitch device for sock extraction
- Antitwist device
- Footlet device
- Inside-out sock ejection device
- G-Flot device
- G-Flot 2 device
- Elastane extra pliers device
- Recover yarn device, 6 positions
- Yarn trimming circular cutter with adjustable speed
- Lower sock-turning device with rotating tube
- Linking device and yarnfingers inspection led lamps
- Preparation for storage feeder "Unifeeder 2" by BTR
- Ethernet board for connection to Dinema Nautilus data collector system
- Second elastic yarn finger on second feed.
- Yarn sliding control sensors, Dinema ISPY
- Pneumatic yarn tensioner for covered elastane
- Suction fan

POSSIBLE KNITTING

The standard machine can perform the following knittings

- Mesh, tuck and float stitch jacquard, in two feeds, plain knit or terry.
- Five colors pattern plus ground color, mesh, tuck and float stitch, single feed, plain knit or terry.
- With laid-in elastic: five colors pattern plus ground color, tuck and float stitch, single feed, plain knit or terry.
- With laid-in elastic: four colors pattern plus ground color, mesh, tuck and float stitch, single feed, plain knit or terry.
- Laid-in elastic in two feeds, one elastic course every two knitted courses.
- With the second elastic yarn finger, four colors pattern on course plus ground, tuck and float stitch, one feed, plain knit or terry.
- With the second elastic yarn finger, three colors pattern on course plus ground, mesh, tuck and float stitch, single feed, plain knit or terry.

SINGLE CYLINDER

GE625DF

Lonati

NUMBER OF COLORS

Number of colors	5 colors on course plus ground color, one feed
------------------	--

PERFORMANCES

		3" 3/4 CYLINDERS
KNITTING FEATURES		Patterns or selections 250 rpm
		Plain knit sinker cap 250 rpm
MAXIMUM SPEED		250 rpm

Above data are indicative and not binding.

DISCLAIMER: maximum speed may vary depending on yarn, knitting, lubrication etc

GAUGE

		GAUGE																					
Model	ø	6½	7	7½	8	8½	9	9½	10	10½	11	11½	12	12½	13	13½	14	14½	15	15½	16	16½	17
							108	112	116	120 128	132	136	144		156	160	168		176	180	188	192	200
GE625DF	3"3/4	Needle thickness 0.85 mm																					
		Needle thickness 0.70 mm															Needle thickness 0.60 mm						

Above data are indicative and not binding.

DISCLAIMER:

All features in the brochure are for information only and subject to change without any prior notice.

For a complete list of available options, please contact Lonati sales network.

The Company accepts no liability for improper use of machinery.

Lonati is recommending needles from

GROZ-BECKERT®

SINGLE CYLINDER

GE625DF

NOISE LEVEL (Maximum noise output for GE series models)

Noise pressure level on reference surface = LPA 79,5 dB - Noise power level = LWA 96,6 dB - Peak= 109,3 dB

LUBRICANTS

Average consumption for 100 dozens= 270 gr. Lonati recommends: Kluber Madol 183 Supreme - Fuchs Renolin Trax 16C - VICKERLUBE SOCK 46

GREASE

For seals, bearings etc: Lonati recommends: TechnolubeSeals Damping grease Nyogel 774F-1

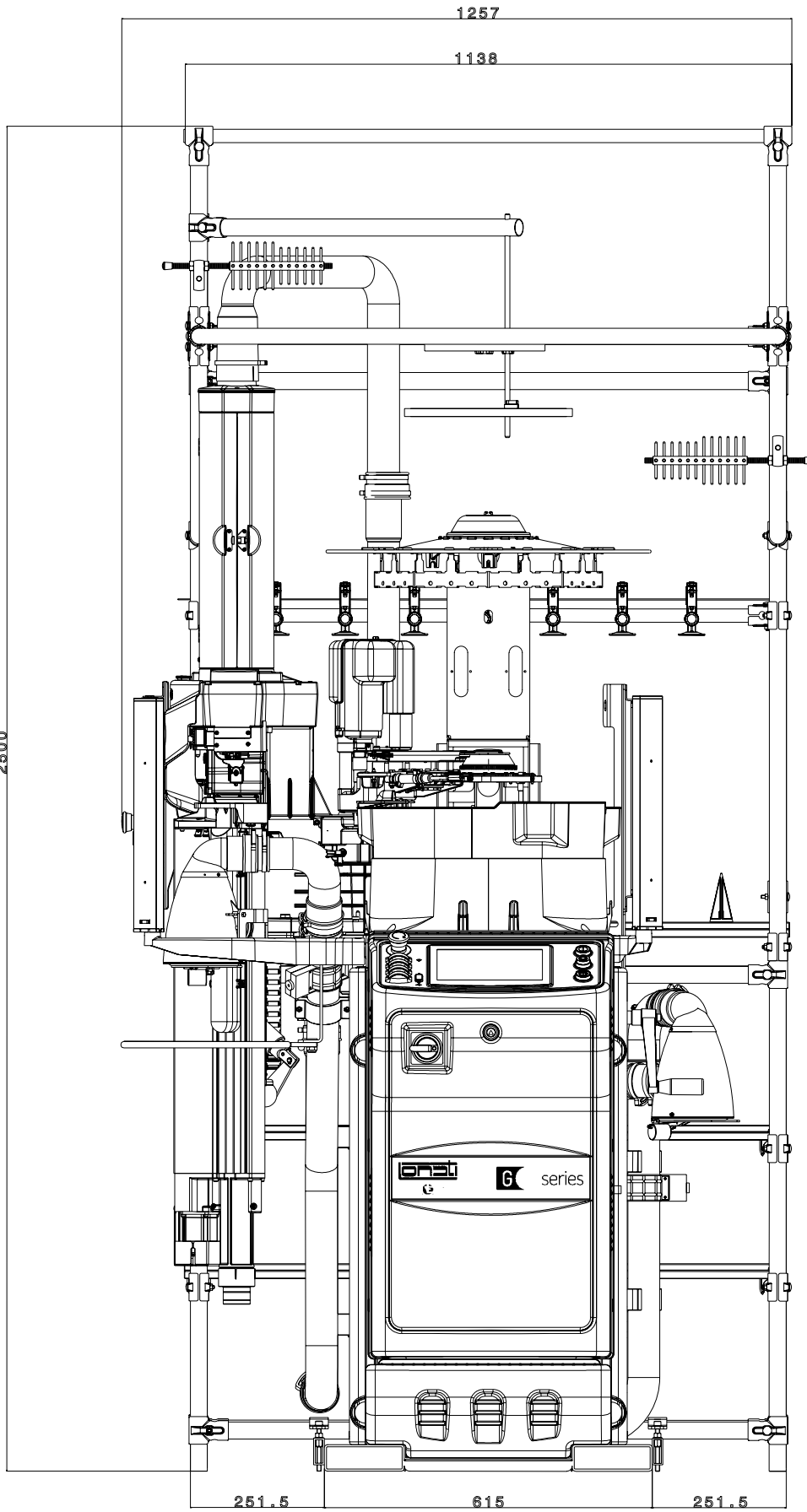

DESCRIPTION	CODE	NR. OF REELS	WEIGHT KG.	NOTES
Yarn creel	G3930706	23	51	Standard version
Yarn creel	G3930707	23	51	Version with BTR sensors

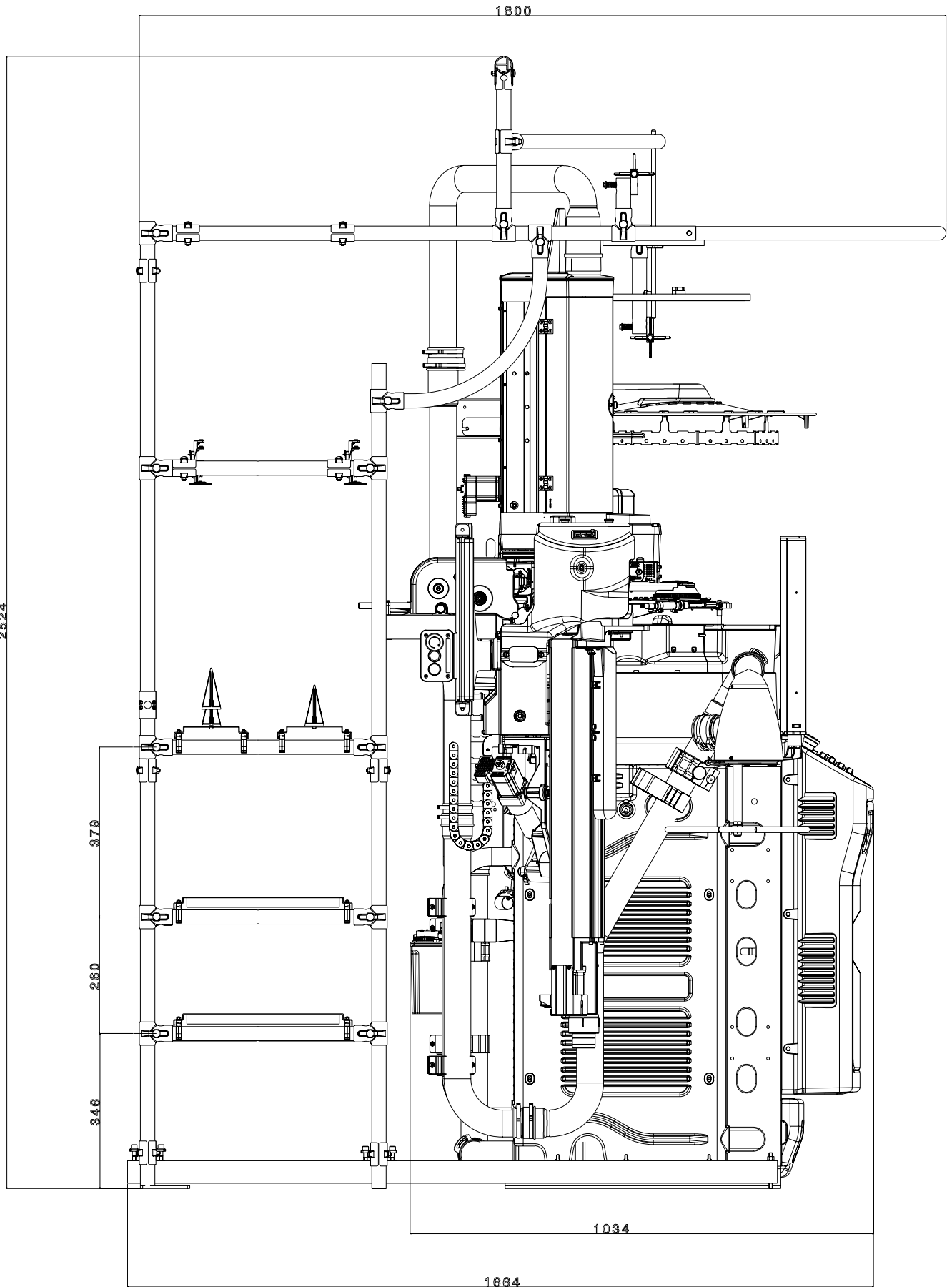

DESCRIPTION	CODE	NR. OF REELS	WEIGHT KG.	NOTES
Yarn creel	G3930706	23	51	Standard version
Yarn creel	G3930707	23	51	Version with BTR sensors

Lonati

