

**G** **E** series

SINGLE CYLINDER

GE544H



Lonati

# SINGLE CYLINDER GE544H

**SBYS DEVICE**  
for automatic linking,  
increased reliability  
and productivity  
compared to the  
previous series

**KNITTING HEAD**  
designed to knit high quality  
items and ensure constant  
reliability over time.

**STEPPING  
MOTORS**  
with absolute  
encoder for  
angular position  
control

**NEW ELECTRONICS**  
9" high resolution touch  
screen display. New  
user friendly interface.  
Ethernet, WiFi, NFC  
connections, Bluetooth is  
also available for future  
developments

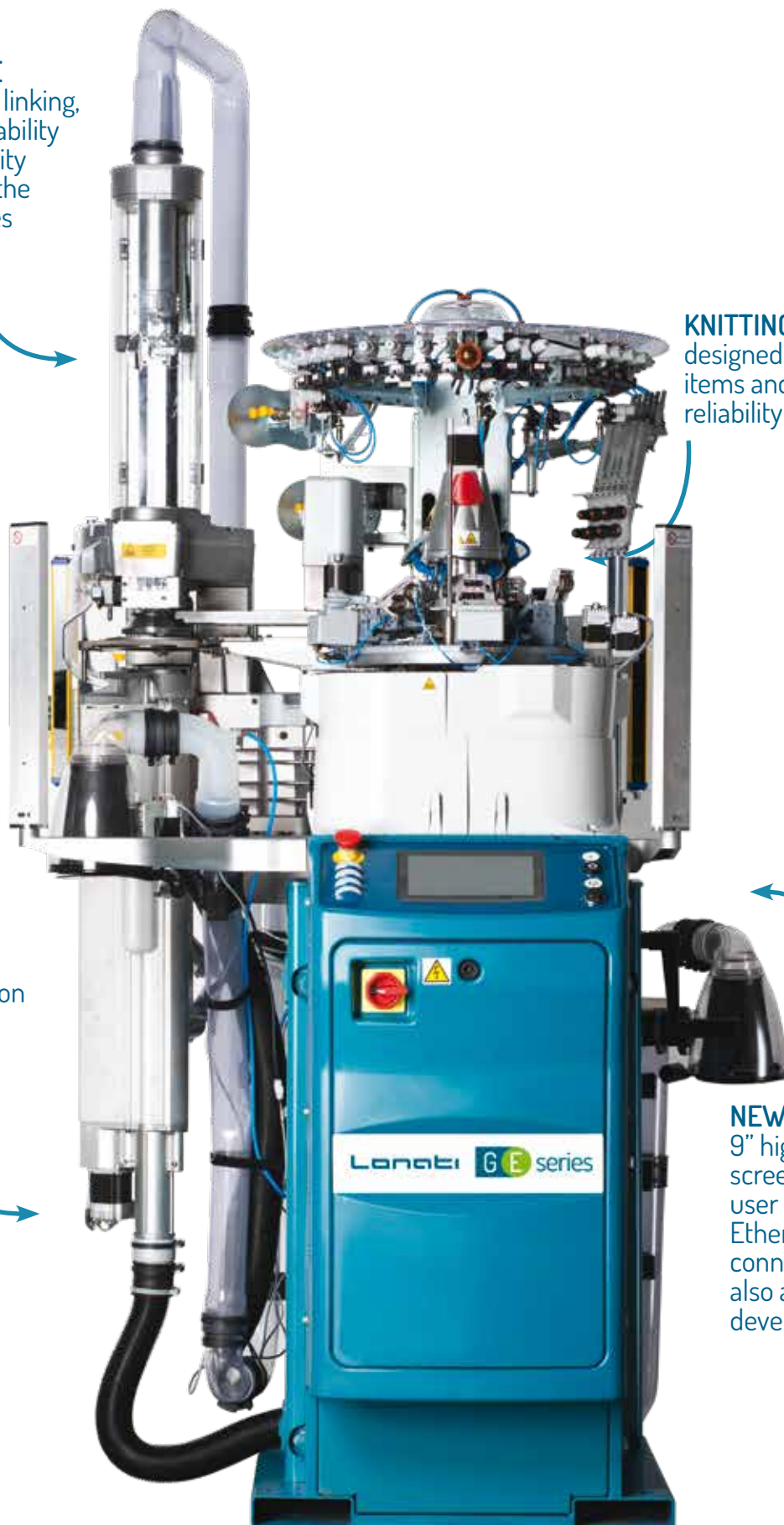

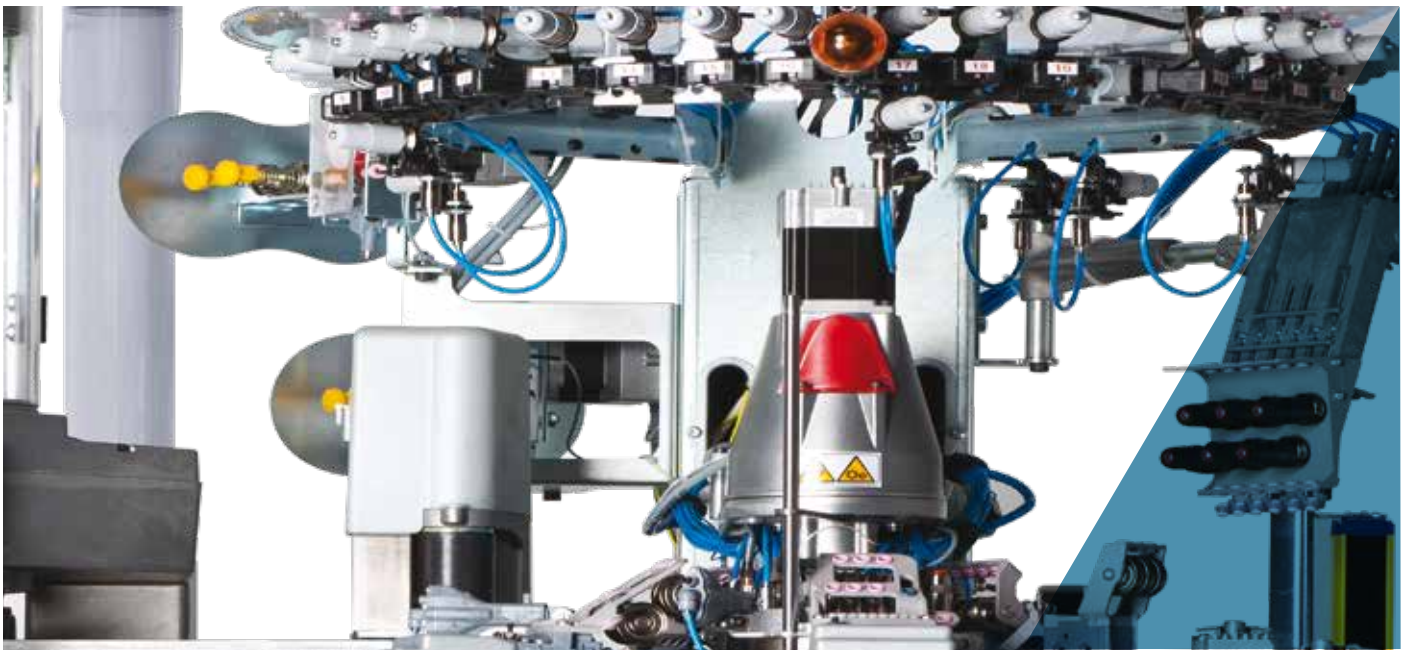

All images in this brochure are indicative and not binding.

## SINGLE CYLINDER GE544H

4 feeds single cylinder for men's socks machines are designed to offer maximum productivity. They are available in 4" diameter with different numbers of needles. Automatic linking with the latest version of the SBYS device, performing a "real linking" technique. Advantages are remarkable: superior quality sock finishing, more comfort and resistance compared to socks made using conventional systems. New electronics provides control and execution of all machine commands. Drawings and articles are created and managed by Digraph 3 Plus software package, which contains a full collection of styles the operator can combine in different ways to obtain the desired results.

- 4 colors pattern on one course on single feed, plain knit
- Reciprocated heel and toe in different sizes
- 27 yarnfingers
- Rising dial and finger plate with stepping motor
- 9 electronic actuators for needle selection
- Brushless coaxial main motor

### MACHINE DIMENSIONS



Lenght max 127.3 cm  
Depth max 114.8 cm  
Height max 228 cm

### MACHINE WEIGHT



ca. 320 Kg

# SINGLE CYLINDER

## GE544H

### TECHNICAL DATA

MODEL	CYLINDER DIAMETER	GAUGE	NEEDLE THICKNESS
GE544H	4"	from 8 1/2 to 19	0.85 - 0.70 - 0.60 mm

Above data are indicative and not binding.

### STANDARD DEVICES

- Stepper motor electric dial with adjustable height
- Stitch cam feeds: 1,2,3,4 with 2 different heights
- High speed motorized sinker cap
- 9" high resolution touch screen display
- Yarn sliding sensors guard cleaning device
- Heel yarn recover device with four positions
- 2 stepper motor controlled adjustable suction valves
- 9 yarnfingers on first feed, 6 on second, third, fourth feed
- Yarn creel
- USB port
- Circular yarn cutter with mechanical stop

### MAIN OPTIONAL DEVICES

- LGL Eco Power or Eco Compact yarn storage feeder, also available with "Attivo" electronic brake version
- Dinema GRYF positive yarn feeders
- Elastic yarn positive feeders, for compression socks
- Dinema Plus elastan positive feeders
- Stitch cam feeds: 1,2,3,4 with 3 different height.
- Motorized stitch cams
- Motorized raising stitch device for sock extraction
- Motorized sinker cap for sinker pressure
- Motorized sinker cap for sinker pressure and angular position
- Antitwist device
- Footlet device
- Inside-out sock ejection device
- Recover yarn device, 6 positions
- Yarn trimming circular cutter with adjustable speed
- Lower sock-turning device with rotating tube
- Linking device and yarnfingers inspection led lamps
- Dial with 5 pliers for bare or coated elastane
- Preparation for storage feeder "Unifeeder 2" by BTSR
- Ethernet board for connection to Dinema Nautilus data collector system
- Yarn sliding control sensors, Dinema ISPY
- 4 feeds for reinforced sole
- Pneumatic yarn tensioner for covered elastane
- Suction fan

### POSSIBLE KNITTING

The standard machine can perform the following knittings

- 4 colors pattern plus ground color, tuck and float stitch, 1 feed
- 3 colors pattern plus ground color, mesh, tuck and float stitch, 1 feed
- With laid-in elastic: 3 colors pattern plus ground color, tuck and float stitch
- With laid-in elastic: 2 colors pattern plus ground color, tuck and float stitch
- Tuck and float stitch, jacquard, 4 feeds
- Elastic on 2 feeds
- Mesh on 2 feeds

# SINGLE CYLINDER

## GE544H

Lonati

### NUMBER OF COLORS

Number of colors	4 colors on course plus ground color, one feed
------------------	--

### PERFORMANCES

	4" CYLINDER
KNITTING FEATURES	patterns or selections 300 rpm plain mesh without pattern 350 rpm
MAXIMUM SPEED	350 rpm

Above data are indicative and not binding.

DISCLAIMER: maximum speed may vary depending on yarn, knitting, lubrication etc

### GAUGE

		GAUGE																										
Model	ø	6½	7	7½	8	8½	9	9½	10	10½	11	11½	12	12½	13	13½	14	14½	15	15½	16	16½	17	17½	18	18½	19	20
GE544H	4"					108		116		132		144		156		168	176	180	188	192	200		216	220			240	
		Needle thickness 0.85 mm																										
		Needle thickness 0.70 mm												Needle thickness 0.60 mm														

Above data are indicative and not binding.

**DISCLAIMER:**

All features in the brochure are for information only and subject to change without any prior notice.

For a complete list of available options, please contact Lonati sales network.

The Company accepts no liability for improper use of machinery.

Lonati is recommending needles from  
**GROZ-BECKERT®**

# SINGLE CYLINDER

GE544H

## NOISE LEVEL (Maximum noise output for GE series models)

Noise pressure level on reference surface = LPA 79,5 dB - Noise power level = LWA 96,6 dB - Peak= 109,3 dB

## LUBRICANTS

Average consumption for 100 dozens= 270 gr. Lonati recommends: Kluber Madol 183 Supreme - Fuchs Renolin Trax 16C - VICKERLUBE SOCK 46

## GREASE

For seals, bearings etc: Lonati recommends: TechnolubeSeals Damping grease Nyogel 774F-1

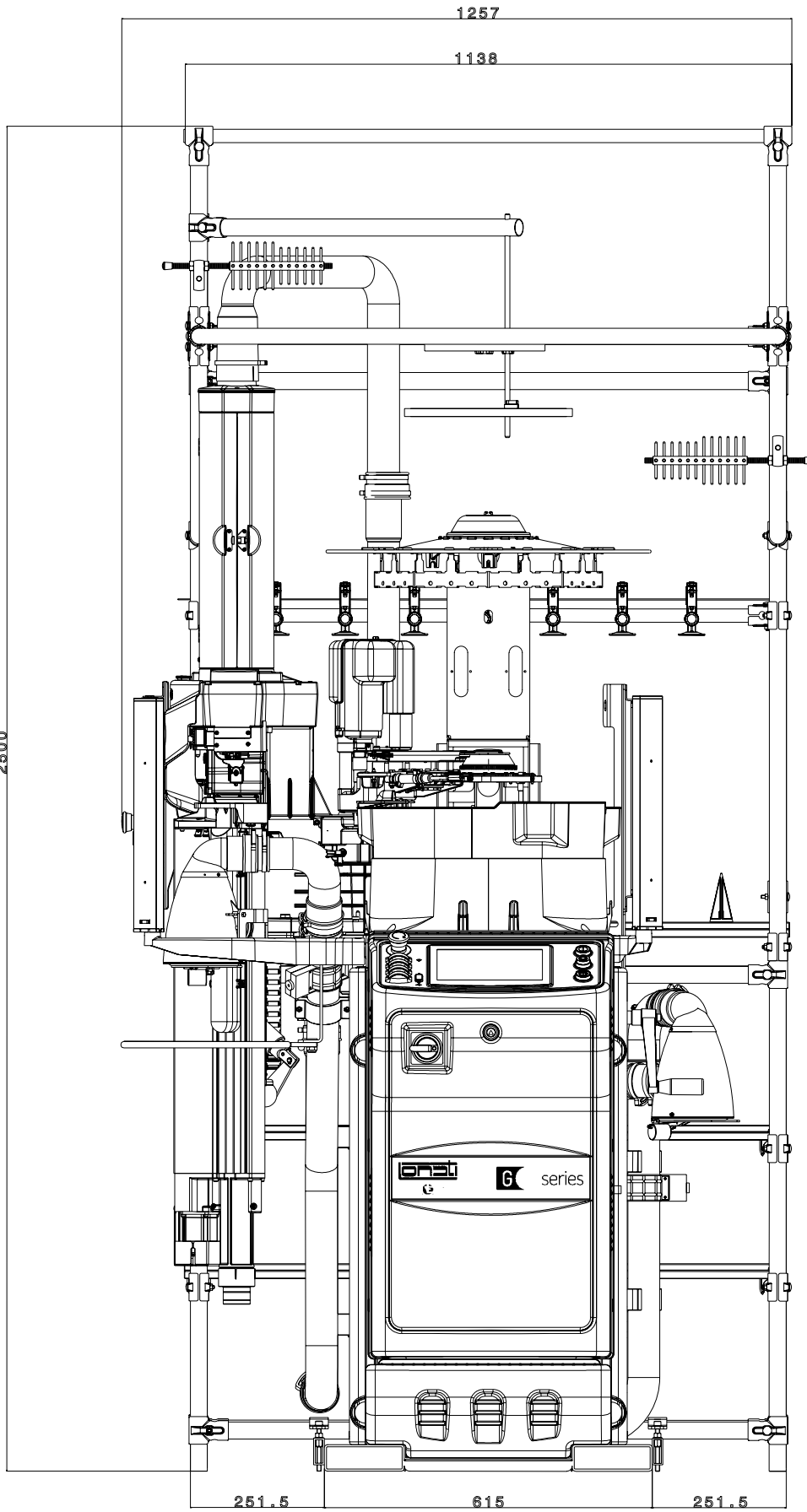

DESCRIPTION	CODE	NR. OF REELS	WEIGHT KG.	NOTES
Yarn creel	G3930706	23	51	Standard version
Yarn creel	G3930707	23	51	Version with BTR sensors

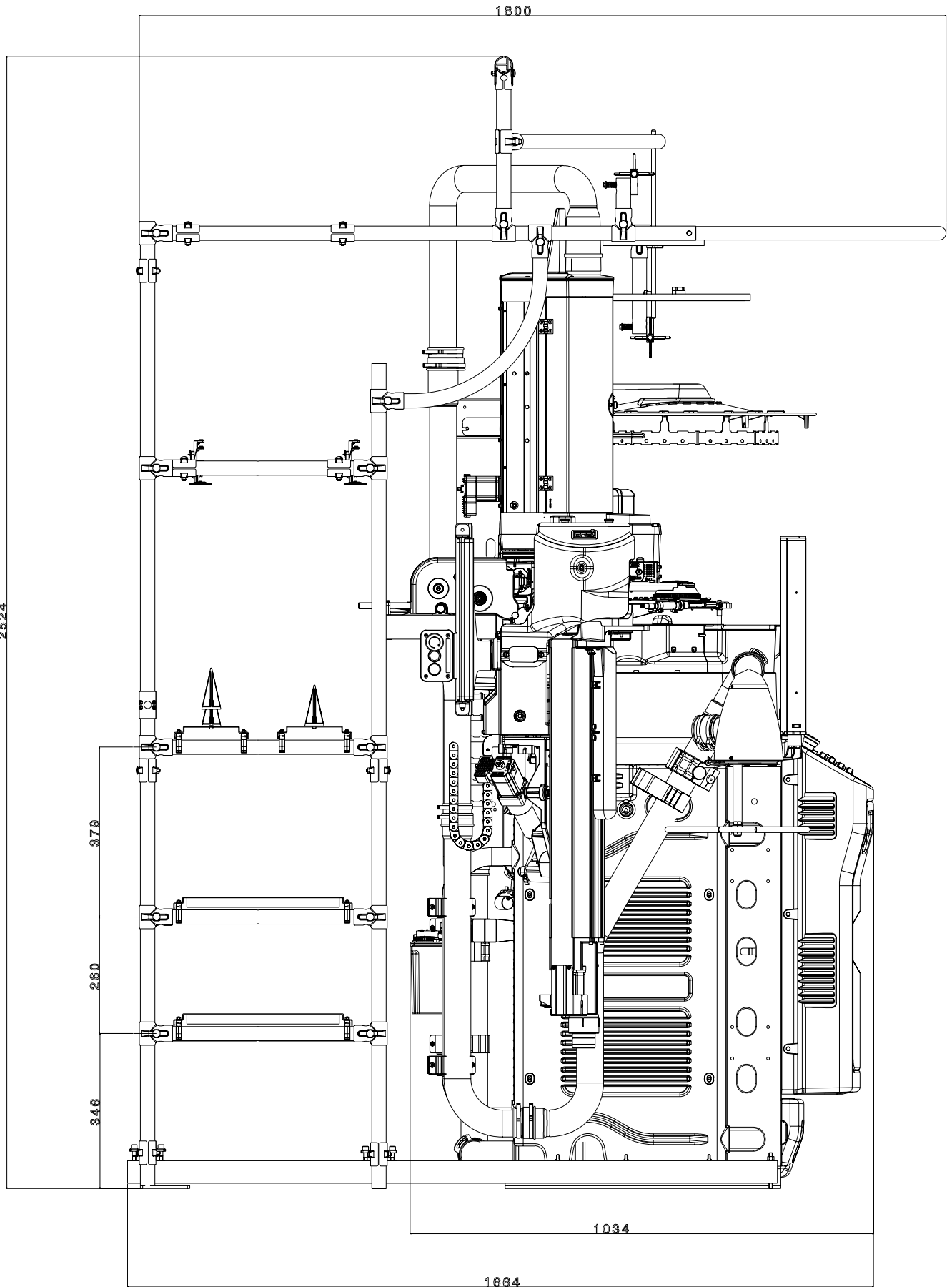

DESCRIPTION	CODE	NR. OF REELS	WEIGHT KG.	NOTES
Yarn creel	G3930706	23	51	Standard version
Yarn creel	G3930707	23	51	Version with BTR sensors



Lonati

