

G **E** series

SINGLE CYLINDER

GE523F



Lonati

SINGLE CYLINDER GE523F

SBYS DEVICE

for automatic linking,
increased reliability and
productivity compared
to the previous series.

KNITTING HEAD

designed to knit high quality
items and ensure constant
reliability over time

STEPPING MOTORS

with absolute encoder
for angular position
control.

NEW ELECTRONICS

9" high resolution
touch screen
display. New user
friendly interface.
Ethernet, WiFi,
NFC connections,
Bluetooth is also
available for future
developments.



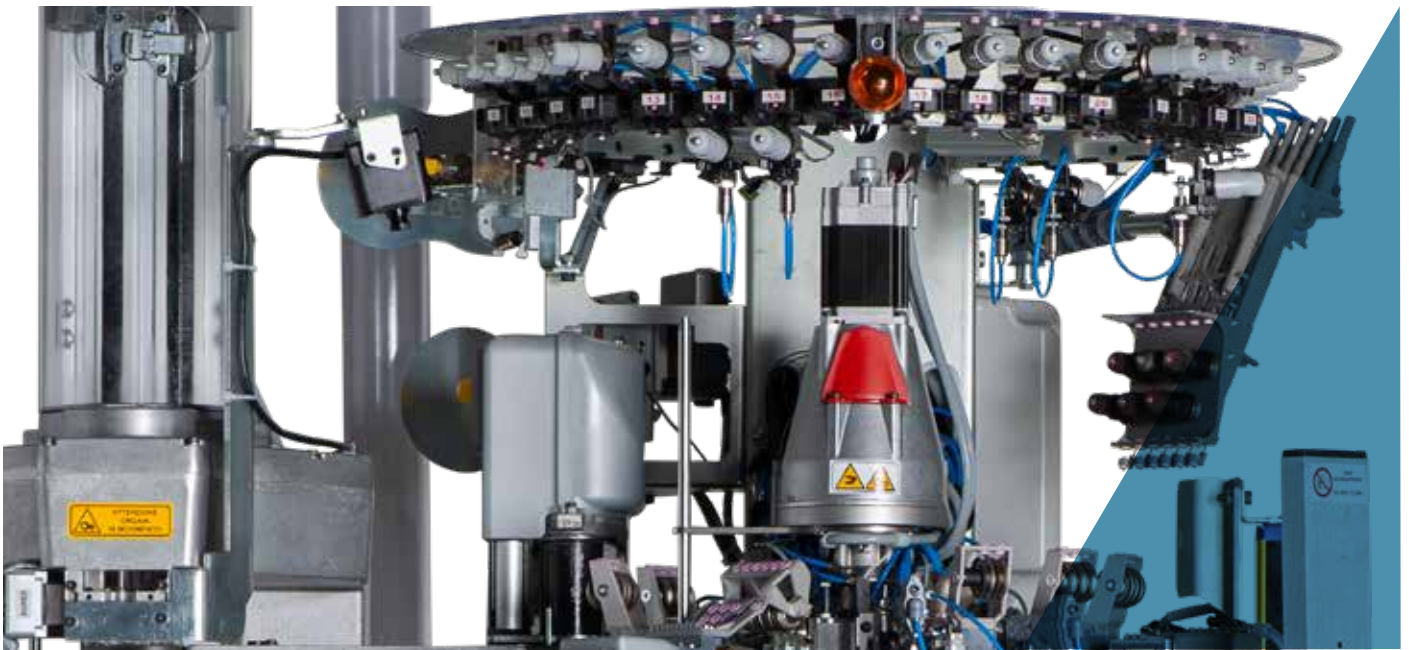

All images in this brochure are indicative and not binding.

SINGLE CYLINDER GE523F

A new machine for 2 feeds items with 3 colors pattern. Automatic linking with the latest version of the SBYS device, performing a “real linking” technique. Advantages are remarkable: superior quality sock finishing, more comfort and resistance compared to socks made using conventional systems. New electronics provides control and execution of all machine commands. Drawings and articles are created and managed by Digraph 3 Plus software package, which contains a full collection of styles the operator can combine in different ways to obtain the desired results.

- 3 colors pattern with 2 feeds, plain knit or terry
- Reciprocated heel and toe in different sizes and 3D effects
- 36 yarn fingers
- Rising dial and finger plate with stepping motor
- 9 electronic actuators for needle selection
- Brushless coaxial main motor

MACHINE DIMENSIONS



Length max 127.3 cm
Depth max 114.8 cm
Height max 228 cm

MACHINE WEIGHT



ca. 320 Kg

SINGLE CYLINDER

GE523F

TECHNICAL DATA

MODEL	CYLINDER DIAMETER	GAUGE	NEEDLE THICKNESS
GE523F	4"	from 8 1/2 to 16	0.85 - 0.70 - 0.60 mm

Above data are indicative and not binding.

STANDARD DEVICES

- Stepper motor electric dial with adjustable height
- Motorized stitch cams
- Motorized sinker cap for sinker pressure and angular position
- 9" high resolution touch screen display
- Yarn sliding sensors guard cleaning device
- Heel yarn recover device with four positions
- 16 color yarn fingers
- 2 stepper motor controlled adjustable suction valves
- 10 yarn fingers on both stitch feed
- Yarn creel
- USB port
- Circular yarn cutter with mechanical stop
- 2 yarn finger for laid-in elastic

MAIN OPTIONAL DEVICES

- LGL Eco Power or Eco Compact yarn storage feeder, also available with "Attivo" electronic brake version
- Dinema GRYF positive yarn feeders
- Elastic yarn positive feeders, for compression socks
- Dinema Plus elastane positive feeders
- Motorized raising stitch device for sock extraction
- Antitwist device
- Footlet device
- Inside-out sock ejection device
- G-Flot device
- G-Flot 2 device
- Elastane extra pliers device, feed 1 and 2
- Recover yarn device, 6 positions
- Yarn trimming circular cutter with adjustable speed
- Lower sock-turning device with rotating tube
- Linking device and yarnfingers inspection led lamps
- Preparation for storage feeder "Unifeeder 2" by BTSR
- Ethernet board for connection to Dinema Nautilus data collector system
- Yarn sliding control sensors, Dinema ISPY
- Pneumatic yarn tensioner for covered elastane
- Suction fan

POSSIBLE KNITTING

The standard machine can perform the following knittings

- Mesh, tuck and float stitch, jacquard, 2 feeds, plain knit or terry
- 3 colors pattern plus ground color, mesh, tuck and float stitch, jacquard, 2 feeds, plain knit or terry
- 2 colors pattern plus ground color, mesh, tuck and float stitch, jacquard, 2 feeds, plain knit or terry
- With laid-in elastic: 2 colors pattern plus ground color, tuck and float stitch, 2 feed, plain knit or terry
- With laid-in elastic: 1 color pattern plus ground color, mesh, tuck and float stitch, 2 feeds, plain knit or terry

SINGLE CYLINDER GE523F

Lonati

NUMBER OF COLORS

Number of colors	3 colors on course plus ground color, two feeds
------------------	---

PERFORMANCES

	4" CYLINDERS
KNITTING FEATURES	Patterns or selections or terry 300 rpm Plain knit without pattern, "high speed" sinker cap 300 rpm
MAXIMUM SPEED	300 rpm

Above data are indicative and not binding.

DISCLAIMER: maximum speed may vary depending on yarn, knitting, lubrication etc.

GAUGE

Model	ø	GAUGE																					
		6½	7	7½	8	8½	9	9½	10	10½	11	11½	12	12½	13	13½	14	14½	15	15½	16	16½	17
GE523F	4"					108 112		116 120		128 132	136	144		156 160		168	176	180	188	192	200		
		Needle thickness 0.85 mm																					
		Needle thickness 0.70 mm										Needle thickness 0.70 mm				Needle thickness 0.60 mm							

Above data are indicative and not binding.

DISCLAIMER:

All features in the brochure are for information only and subject to change without any prior notice.

For a complete list of available options, please contact Lonati sales network.

The Company accepts no liability for improper use of machinery.

Lonati is recommending needles from
GROZ-BECKERT®

SINGLE CYLINDER

GE523F

NOISE LEVEL (Maximum noise output for GE series models)

Noise pressure level on reference surface = LPA 79,5 dB - Noise power level = LWA 96,6 dB - Peak= 109,3 dB

LUBRICANTS

Average consumption for 100 dozens= 270 gr. Lonati recommends: Kluber Madol 183 Supreme - Fuchs Renolin Trax 16C - VICKERLUBE SOCK 46

GREASE

For seals, bearings etc: Lonati recommends: TechnolubeSeals Damping grease Nyogel 774F-1

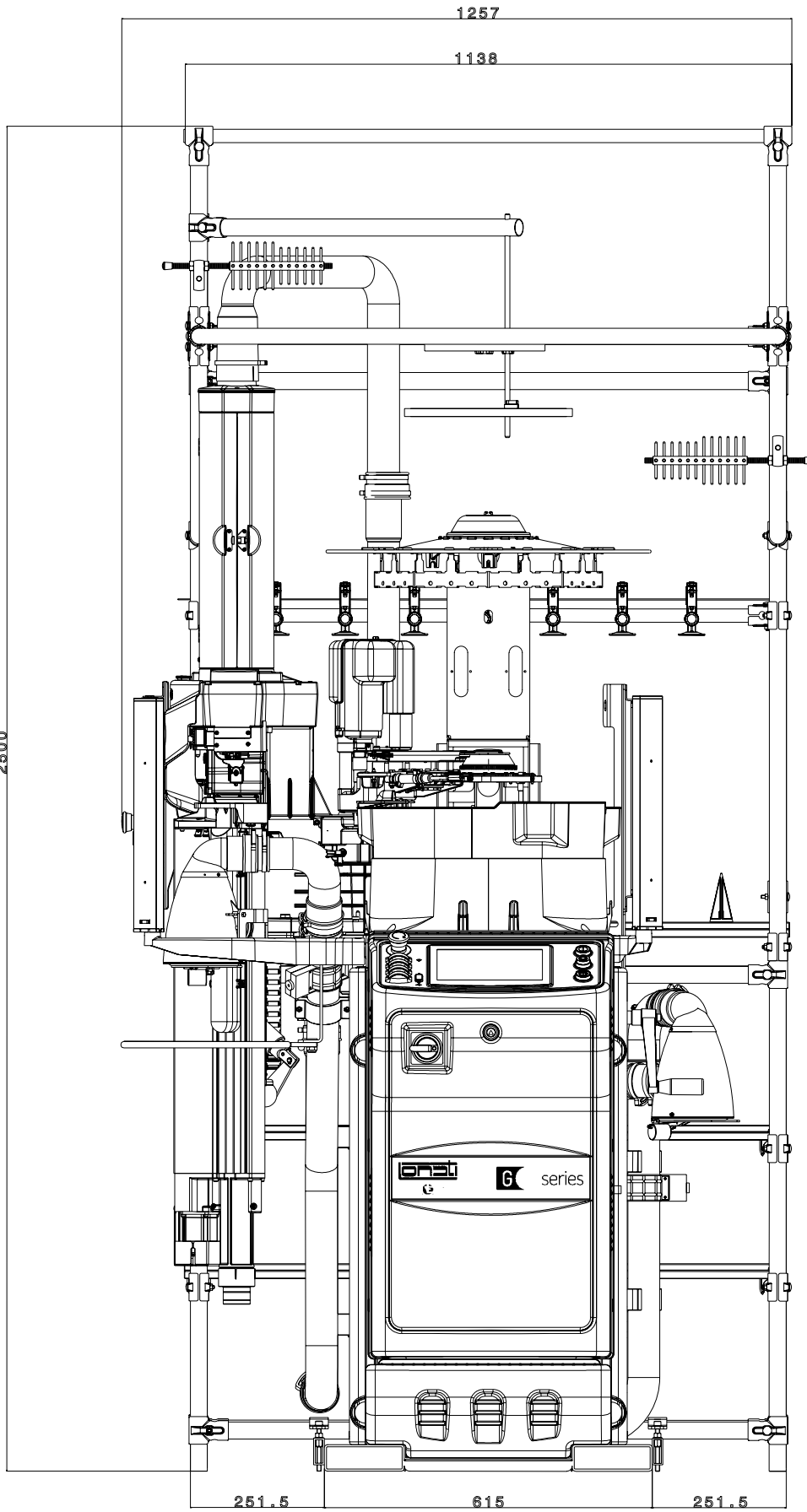

DESCRIPTION	CODE	NR. OF REELS	WEIGHT KG.	NOTES
Yarn creel	G3930706	23	51	Standard version
Yarn creel	G3930707	23	51	Version with BTR sensors

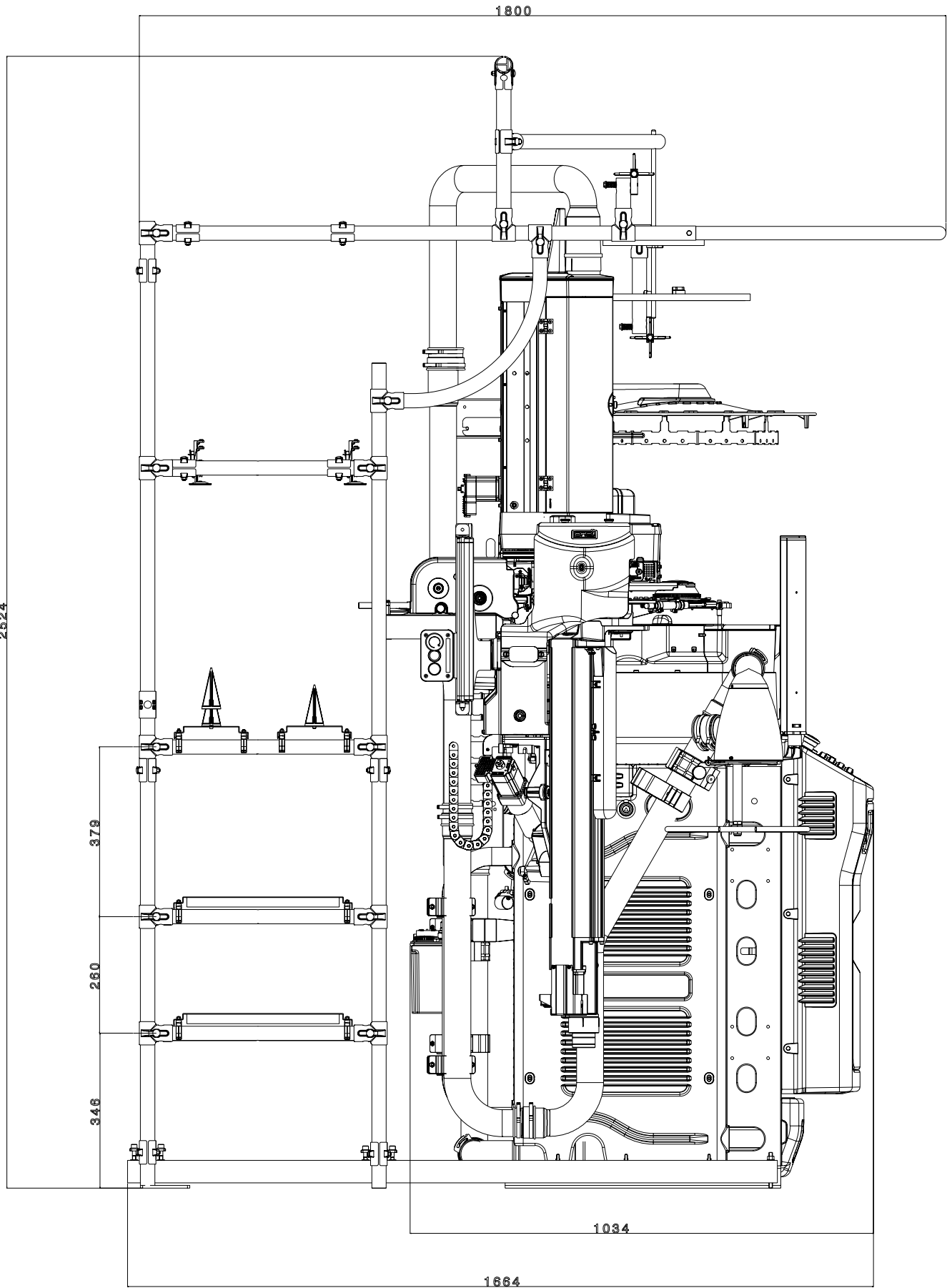

DESCRIPTION	CODE	NR. OF REELS	WEIGHT KG.	NOTES
Yarn creel	G3930706	23	51	Standard version
Yarn creel	G3930707	23	51	Version with BTR sensors

Lonati

