

**G** **E** series

SINGLE CYLINDER

GE523 0



Lonati

# SINGLE CYLINDER

GE523 0



**KNITTING HEAD**  
designed to knit high quality items and ensure constant reliability over time

**SINKERS CAP**  
high speed for higher production

**NEW ELECTRONICS**  
9" high resolution touch screen display. New user friendly interface. Ethernet, WiFi, NFC connections, Bluetooth is also available for future developments



All images in this brochure are indicative and not binding.

## SINGLE CYLINDER GE523 0

A new machine for 2 feeds items with 3 colors pattern. New electronics provides control and execution of all machine commands. Drawings and articles are created and managed by Digraph 3 Plus software package, which contains a full collection of styles the operator can combine in different ways to obtain the desired results.

- 3 colors pattern with 2 feeds, plain knit
- Reciprocated heel and toe in different sizes and 3D effects
- 36 yarn fingers
- Rising dial and finger plate with stepping motor
- 10 electronic actuators for needle selection
- Brushless coaxial main motor

### MACHINE DIMENSIONS



Length max 94.5 cm  
Depth max 103.3 cm  
Height max 180 cm

### MACHINE WEIGHT



ca. 230 Kg

# SINGLE CYLINDER

## GE523 0

### TECHNICAL DATA

MODEL	CYLINDER DIAMETER	GAUGE	NEEDLE THICKNESS
GE523 0	4"	from 6 1/2 to 20	0.85 - 0.70 - 0.60 mm

Above data are indicative and not binding.

### STANDARD DEVICES

- Stepper motor electric dial with adjustable height
- Motorized stitch cams
- Motorized sinker cap for sinker pressure and angular position
- 9" high resolution touch screen display
- Yarn sliding sensors guard cleaning device
- Heel yarn recover device with four positions
- 2 yarn fingers for laid-in elastic
- 9 yarn fingers on both stitch feed
- Yarn creel
- USB port
- 16 color yarn fingers
- Circular yarn cutter with mechanical stop
- Stepper motor controlled adjustable suction valve

### MAIN OPTIONAL DEVICES

- LGL Eco Power or Eco Compact yarn storage feeder, also available with "Attivo" electronic brake version
- Dinema GRYF positive yarn feeders
- Elastic yarn positive feeders, for compression socks
- Dinema Plus elastane positive feeders
- Antitwist device
- Footlet device
- Elastane extra pliers device, feed 1 and 2
- Led inspections lamps
- Recover yarn device, 6 positions
- Yarn trimming circular cutter with adjustable speed
- Preparation for storage feeder "Unifeeder 2" by B TSR
- Ethernet board for connection to Dinema Nautilus data collector system
- Yarn sliding control sensors, Dinema ISPY
- Pneumatic yarn tensioner for covered elastane
- Suction fan

### POSSIBLE KNITTING

The standard machine can perform the following knittings

- Mesh, tuck and float stitch, jacquard, 2 feeds, plain knit
- 3 colors pattern plus ground color, tuck and float stitch, jacquard, 2 feeds, plain knit
- 2 colors pattern plus ground color, mesh, tuck and float stitch, jacquard, 2 feeds, plain knit
- With laid-in elastic: 2 colors pattern plus ground color, tuck and float stitch, 2 feed, plain knit
- With laid-in elastic: 1 color pattern plus ground color, mesh, tuck and float stitch, 2 feeds, plain knit

# SINGLE CYLINDER

## GE523 0

Lonati

### NUMBER OF COLORS

Number of colors	3 colors on course plus ground color, two feeds
------------------	---

### PERFORMANCES

	4" CYLINDRES
KNITTING FEATURES	Patterns or selections or terry 300 rpm
MAXIMUM SPEED	300 rpm

Above data are indicative and not binding.

DISCLAIMER: maximum speed may vary depending on yarn, knitting, lubrication etc.

### GAUGE

		GAUGE																											
Model	ø	6½	7	7½	8	8½	9	9½	10	10½	11	11½	12	12½	13	13½	14	14½	15	15½	16	16½	17	17½	18	18½	19	20	
GE523 0	4"	84	88	96		108 112		116 120		128 132	136	144		156 160		168	176	180	188	192	200		216	220				240	256
		Spessore ago 0.85 mm																											
		Spessore ago 0.70 mm							Spessore ago 0.70 mm						Spessore ago 0.60 mm														

Above data are indicative and not binding.

#### DISCLAIMER:

All features in the brochure are for information only and subject to change without any prior notice.

For a complete list of available options, please contact Lonati sales network.

The Company accepts no liability for improper use of machinery.

Lonati is recommending needles from  
**GROZ-BECKERT®**

# SINGLE CYLINDER

## GE523 0

### NOISE LEVEL (Maximum noise output for GE series models)

Noise pressure level on reference surface = LPA 79,5 dB - Noise power level = LWA 96,6 dB - Peak= 109,3 dB

### LUBRICANTS

Average consumption for 100 dozens= 270 gr. Lonati recommends: Kluber Madol 183 Supreme - Fuchs Renolin Trax 16C - VICKERLUBE SOCK 46

### GREASE

For seals, bearings etc: Lonati recommends: TechnolubeSeals Damping grease Nyogel 774F-1

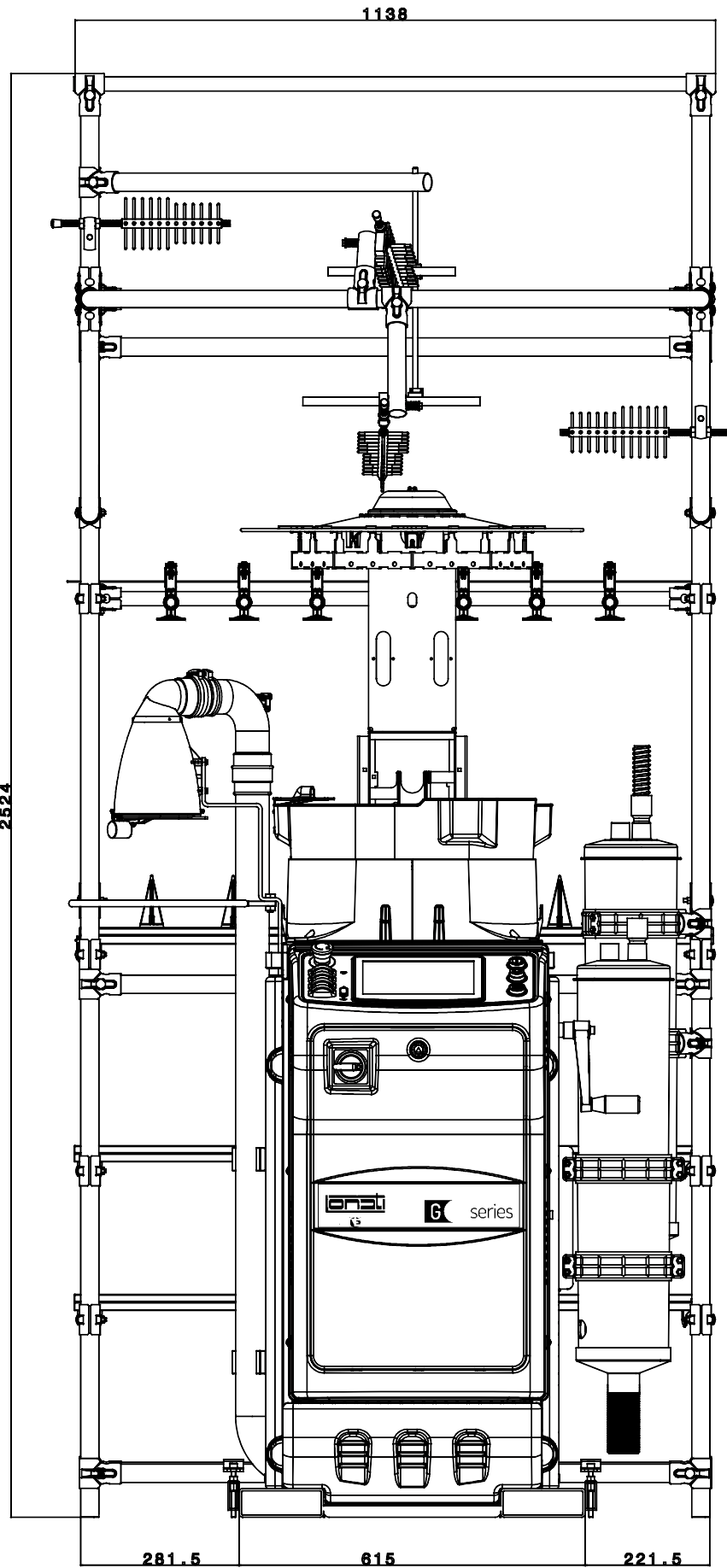

DESCRIPTION	CODE	NR. OF REELS	WEIGHT KG.	NOTES
Yarn creel	G3930706	23	20	Standard version
Yarn creel	G3930707	23	20	Version with BTR sensors

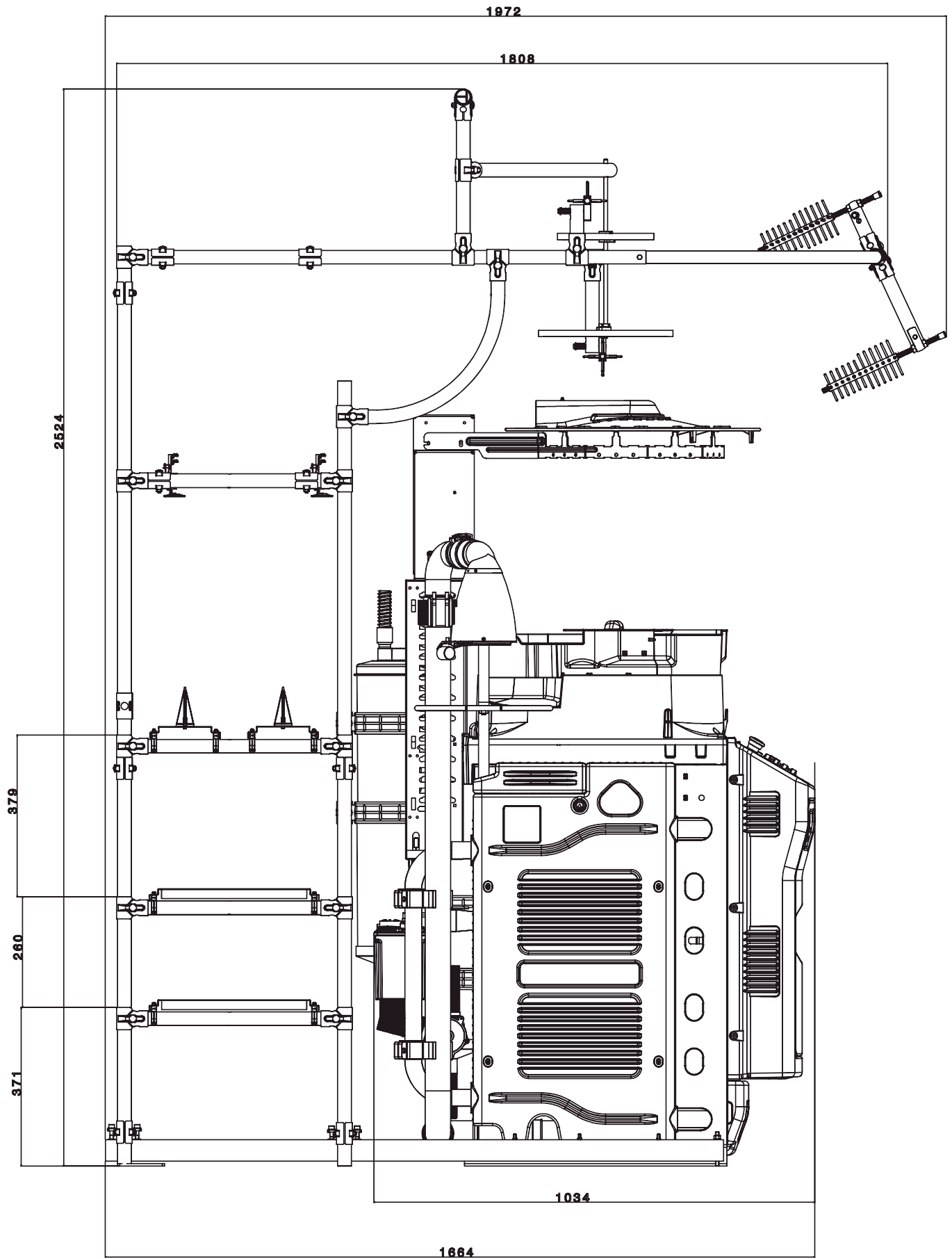

DESCRIPTION	CODE	NR. OF REELS	WEIGHT KG.	NOTES
Yarn creel	G3930706	23	20	Standard version
Yarn creel	G3930707	23	20	Version with BTR sensors



Lonati

