

GOSHORES 

DOUBLE CYLINDER
E1530XS



DOUBLE CYLINDER

E1530XS



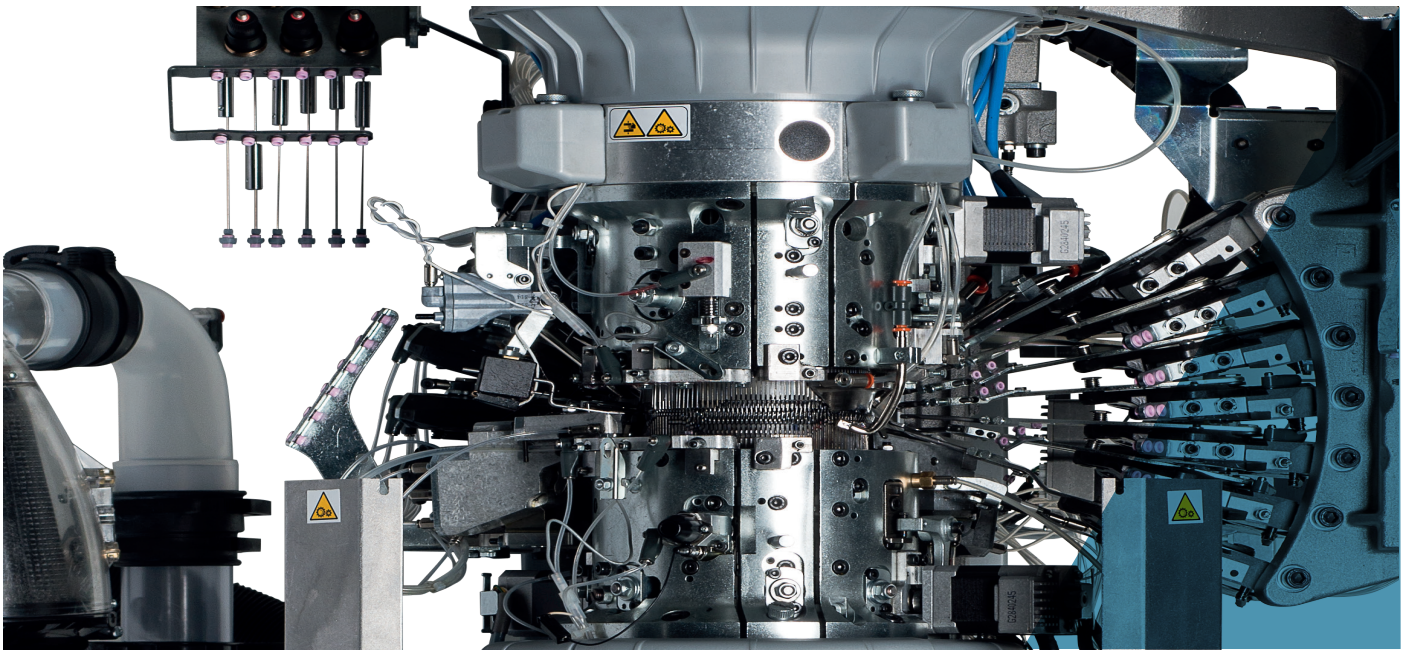

All images in this brochure are indicative and not binding.

DOUBLE CYLINDER E1530XS

High speed Double cylinder machine for seamless shoe uppers production. Mono-magnetic needle by needle selection for different kinds of 3D knitting and patterns. 3D channels made in fabric for high-performance lacing (Lonati Patent). Due to its versatility the machine can produce all kinds of uppers meeting the following advantages:

- No waste produced during knitting
- High speed production to meet international footwear demand
- 100% sustainability when using natural fibers

Different styles and patterns are created and managed by Digraph 3+ Software package

- Needle-needle single-magnet selection instead of pickers and needle droppers and links drums for different rib and links patterns.
- Simplified shell/skirt with less mobile cams
- Mechanical takedown
- Stitch cams with independent stepper motors
- Easier sinkers maintenance thanks to the rotating knitting head.
- Electronic full control of yarnfingers and of all functions.

MACHINE DIMENSIONS



Length cm 90 + yarn creel 32 cm
Depth cm 104 + yarn creel 69 cm
Height 260 cm

MACHINE WEIGHT



Machine ca. 350 Kg
Yarn creel ca. 30 Kg

NOTE:

All data relating to outer appearance, performance, dimensions and weight are just as an indication.

DOUBLE CYLINDER

E1530XS

TECHNICAL DATA

MODEL	CYLINDER DIAMETER	GAUGE	NEEDLE THICKNESS
E1530XS	4"	from 10 to 11	0.9 mm

Above data are indicative and not binding.

STANDARD DEVICES

- Needle-needle single-magnet electronic selection system;
- Mechanical fabric take down;
- Multi-stiffening by means of stepper motor;
- High heel by means of single-magnetic selection;
- Sinker cap with internal lubrication;
- 6 pneumatic yarnfingers;
- 6-rod take-up device;
- Suction valve controlled with stepper motor;
- Selectable open work;
- Split device;

OPTIONAL DEVICES

- Pneumatic yarnfinger number 7
- First yarnfinger positioning at feeds 5,6 and 7
- Second yarnfinger positioning at feeds 2,3 and 4
- Prearrangement for LGL Ecopower feeders
- Prearrangement for BTR UNIFEEDER2
- LGL Ecopower feeders
- ISPY sensors
- Cassefils mechanical sensors
- Second elastic feeder
- Knots control
- Ethernet board
- Patterned shadow stripe knit
- Double plaiting on 1st and 2nd feed
- Suction fan
- Pulldown sensors

SUITABLE YARNS

The machine is designed to be used with the following yarns

- Natural fibers
- Synthetic yarn
- Elastic yarn

POSSIBLE KNITTING

The standard machine can perform the following knittings

- Plain Fabric
- Rib
- Links
- Links Jacquard
- 1st feed tuck stitch
- Open work fabric
- Half cardigan fabric (option)

DOUBLE CYLINDER E1530XS

NUMBER OF COLORS

Number of colors

In jacquard 2 colors on the same course
Up to 5 colors on first feed
Up to 3 colors on second feed

PERFORMANCES

	4" CYLINDER DIAMETER
GAUGE	10- 11 (needle thickness 0.9 mm)
KNITTING FEATURES	LINKS = 120 Rpm
	Rib and plain knit = 120 Rpm
	Reciprocated motion = 120 Rpm
	Jacquard = 120 Rpm

Above data are indicative and not binding.

GAUGES

Model	ø	GAUGE	
		10	11
1530XS	4"	120	132 144
		Needle thickness 0.9	

Above data are indicative and not binding.

DISCLAIMER:

For gauges lower or higher than those in the chart, their maximum speed must be reduced by 10-15%.

Should you use staple fiber, maximum speed has to be detected each time according to the yarn and the item to be produced. For jacquard and Links jacquard, maximum speed has to be detected each time according to the pattern.

DOUBLE CYLINDER

E1530XS

NOISE LEVEL

Machine average noise level, suction included LpA=81.9 dB LwA=99 db

LUBRICANTS

Average consumption for 100 dozens= 330 gr. Lonati recommends: Kluber Madol 183 Supreme

GREASE

For seals, bearing etc Lonati recommends: Damping grease Nyogel 774F

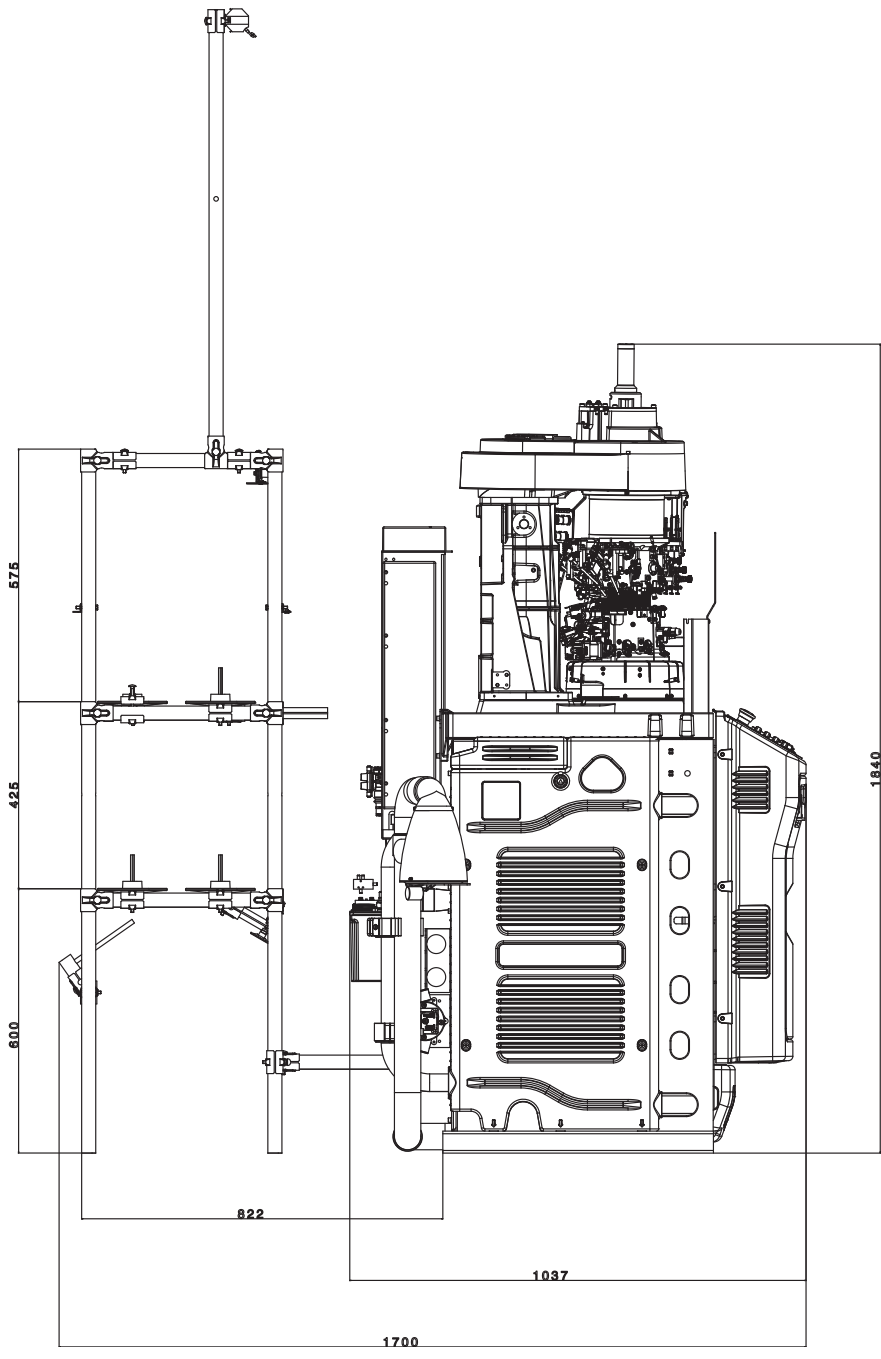

FRONT VIEW

Machine dimensions + 18 positions yarn creel.

NOTE:

The picture may show fittings and equipment that are supplied on demand and not.

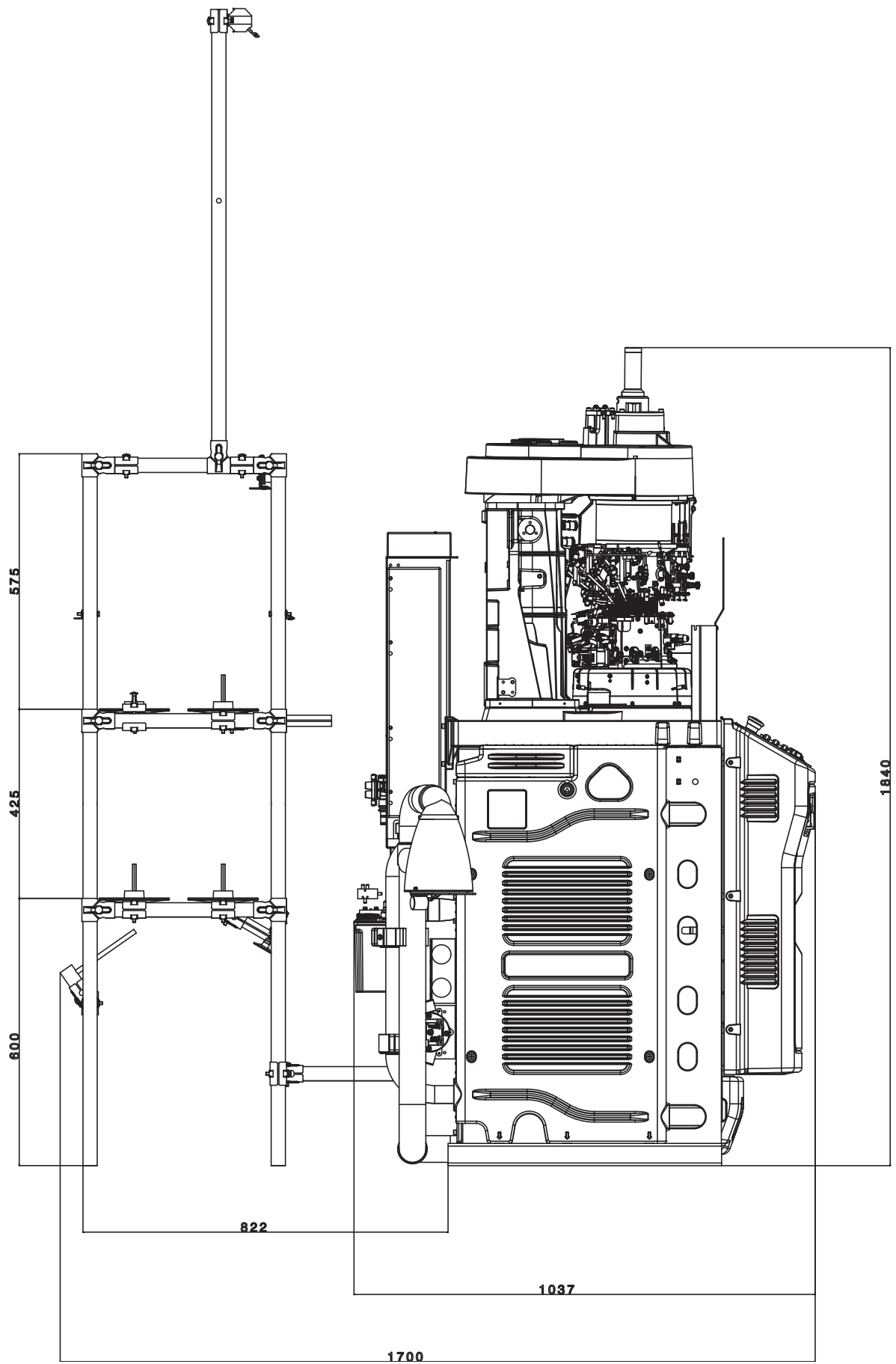

SIDE VIEW

Machine dimensions + 18 positions yarn creel.

NOTE:

The picture may show fittings and equipment that are supplied on demand and not.





LONATI SPA
Via Francesco Lonati, 3 | 25124 Brescia (Italy)
Tel. +39 03023901 | Fax +39 030 2310024
C.F.: 01469680175 | P.iva: 02096730961
info@lonati.com - www.lonati.com